

USER MANUAL

VERSION 1.1 November 2011

EVO-TP4 ***Hardware System***

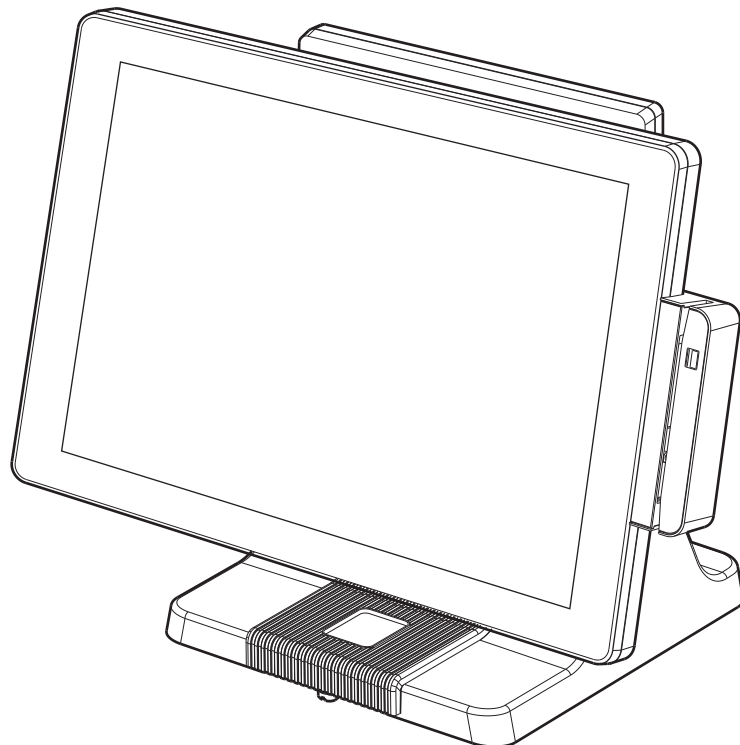

The information contained in this document is subject to change without notice. We make no warranty of any kind with regard to this material, including, but not limited to, the implied warranties of merchantability and fitness for a particular purpose. We shall not be liable for errors contained herein or for incidental or consequential damages in connection with the furnishing, performance, or use of this material.

This document contains proprietary information that is protected by copyright. All rights are reserved. No part of this document may be photocopied, reproduced or translated to another language without the prior written consent of the manufacturer.

TRADEMARK

Intel®, Pentium® and MMX are registered trademarks of Intel® Corporation. Microsoft® and Windows® are registered trademarks of Microsoft Corporation. Other trademarks mentioned herein are the property of their respective owners.

Safety

IMPORTANT SAFETY INSTRUCTIONS

1. To disconnect the machine from the electrical power supply, turn off the power switch and remove the power cord plug from the wall socket. The wall socket must be easily accessible and in close proximity to the machine.
2. Read these instructions carefully. Save these instructions for future reference.
3. Follow all warnings and instructions marked on the product.
4. Do not use this product near water.
5. Do not place this product on an unstable cart, stand, or table. The product may fall, causing serious damage to the product.
6. Slots and openings in the cabinet and the back or bottom are provided for ventilation to ensure reliable operation of the product and to protect it from overheating. These openings must not be blocked or covered. The openings should never be blocked by placing the product on a bed, sofa, rug, or other similar surface. This product should never be placed near or over a radiator or heat register or in a built-in installation unless proper ventilation is provided.
7. This product should be operated from the type of power indicated on the marking label. If you are not sure of the type of power available, consult your dealer or local power company.
8. Do not allow anything to rest on the power cord. Do not locate this product where persons will walk on the cord.
9. Never push objects of any kind into this product through cabinet slots as they may touch dangerous voltage points or short out parts that could result in a fire or electric shock. Never spill liquid of any kind on the product.



This device complies with the requirements of the EEC directive 2004/108/EC with regard to “Electromagnetic compatibility” and 2006/95/EC “Low Voltage Directive”.



This device complies with part 15 of the FCC rules. Operation is subject to the following two conditions:

- (1) This device may not cause harmful interference.
- (2) This device must accept any interference received, including interference that may cause undesired operation.

CAUTION ON LITHIUM BATTERIES

There is a danger of explosion if the battery is replaced incorrectly. Replace only with the same or equivalent type recommended by the manufacturer. Discard used batteries according to the manufacturer’s instructions.



Battery Caution

Risk of explosion if battery is replaced by an incorrectly type. Dispose of used battery according to the local disposal instructions.



Safety Caution

Note: To comply with IEC60950-1 Clause 2.5 (limited power sources, L.P.S) related legislation, peripherals shall be 4.7.3.2 “Materials for fire enclosure” compliant.

4.7.3.2 Materials for fire enclosures

For MOVABLE EQUIPMENT having a total mass not exceeding 18kg.the material of a FIRE ENCLOSURE, in the thinnest significant wall thickness used, shall be of V-1 CLASS MATERIAL or shall pass the test of Clause A.2.

For MOVABLE EQUIPMENT having a total mass exceeding 18kg and for all STATIONARY EQUIPMENT, the material of a FIRE ENCLOSURE, in the thinnest significant wall thickness used, shall be of 5VB CLASS MATERIAL or shall pass the test of Clause A.1

LEGISLATION AND WEEE SYMBOL

2002/96/EC Waste Electrical and Electronic Equipment Directive on the treatment, collection, recycling and disposal of electric and electronic devices and their components.

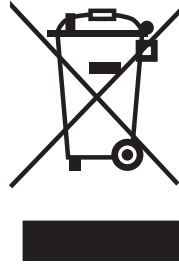

The crossed dust bin symbol on the device means that it should not be disposed of with other household wastes at the end of its working life. Instead, the device should be taken to the waste collection centers for activation of the treatment, collection, recycling and disposal procedure.

To prevent possible harm to the environment or human health from uncontrolled waste disposal, please separate this from other types of wastes and recycle it responsibly to promote the sustainable reuse of material resources.

Household users should contact either the retailer where they purchased this product, or their local government office, for details of where and how they can take this item for environmentally safe recycling.

Business users should contact their supplier and check the terms and conditions of the purchase contract.

This product should not be mixed with other commercial wastes for disposal.

Revision History

Changes to the original user manual are listed below:

Revision	Description	Date
1.0	• Initial release	November 2010
1.1	• C68 MB added	November 2011

Table of Contents

1. Packing List.....	1
1-1. Standard Accessories.....	1
1-2. Optional Accessories	2
2. System View	3
2-1. Front & Side View.....	3
2-2. Rear View with stand.....	3
2-3. I/O Ports View.....	4
2-4. System Dimension.....	5
3. System Assembly & Disassembly	6
3-1. Stand Disassembly.....	6
3-2. Power Adapter Replacement.....	6
3-3. HD Replacement	7
3-4. Open the System.....	8
3-5. RAM Replacement	9
4. Peripheral Installation	10
4-1. MSR Installation	10
4-2. VFD Installation	11
4-3. Second Display Installation	12
4-4. Wall Mounting Kit Installation	13
4-5. Cable Cover Installation	14
4-6. Cash Drawer Installation	15
5. Specifications	17

6. Jumper Setting.....	19
6-1. C48 Motherboard.....	19
6-1-1. Motherboard Layout	19
6-1-2. Connectors & Functions	21
6-1-3. Jumper & BIOS/Utility Setting	22
6-2. B68 Motherboard.....	27
6-2-1. Motherboard Layout	27
6-2-2. Connectors & Functions	28
6-2-3. Jumper Setting	29
6-3. C68 Motherboard.....	32
6-3-1. Motherboard Layout	32
6-3-2. Connectors & Functions	33
6-3-3. Jumper Setting	34

Appendix: Drivers Installation 39

The page is intentionally left blank.

1. Packing List

1-1. Standard Accessories

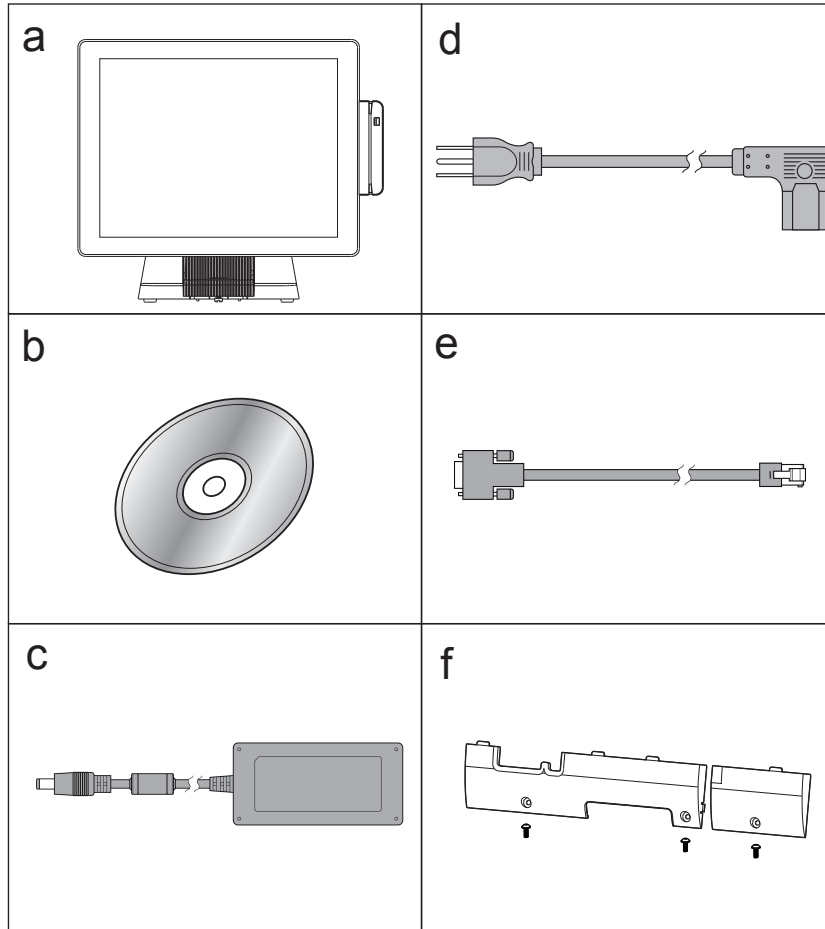

- a. System (with stand)
- b. Driver CD
- c. Power adapter
- d. Power cord
- e. RJ45-DB9 cable (x3)
- f. Cable cover

1-2. Optional Accessories

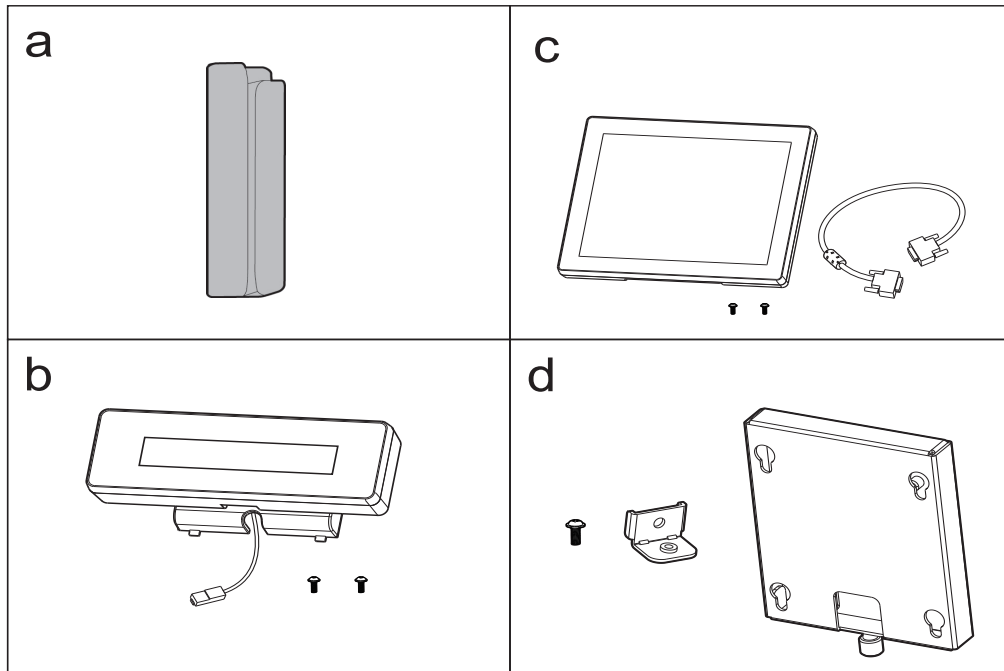

- a. MSR module
- b. VFD module (with RJ-45 cable)
- c. Second display (with VGA cable)
- d. Wall mount kit

2. System View

2-1. Front & Side View

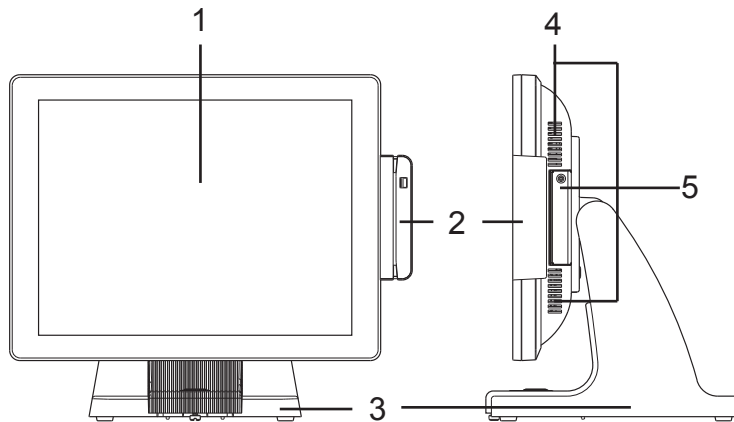

Item No.	Description
1	Touch screen
2	MSR module (<i>optional</i>)
3	Rugged footprint
4	Ventilation
5	HDD door

2-2. Rear View with stand

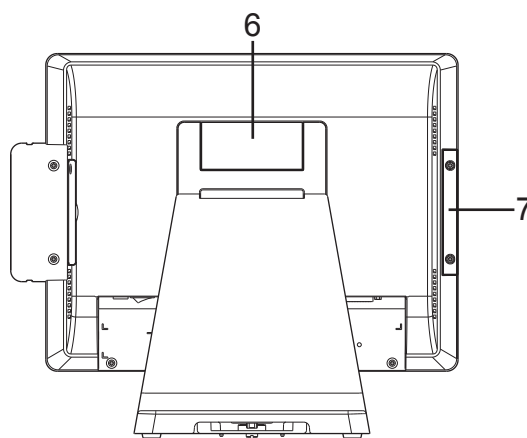

Item No.	Description
6	VFD dummy cover
7	MSR dummy cover

2-3. I/O Ports View

C48 / B68 Motherboard

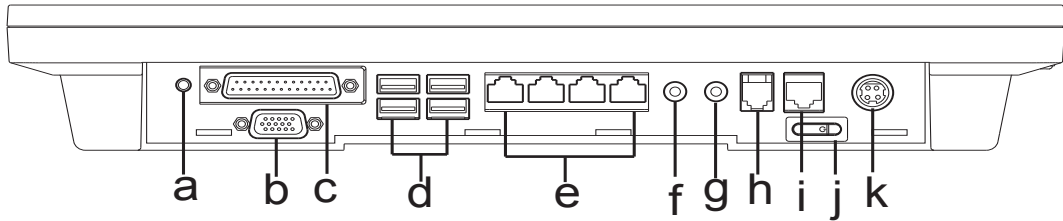

Item No.	Description
a	Power button
b	2nd VGA
c	Parallel
d	USB x 4
e	COM 1, 2, 3, 4 (from right to left)
f	Line-out
g	Mic-in
h	Cash drawer
i	LAN
j	Power switch
k	DC-IN

C68 Motherboard

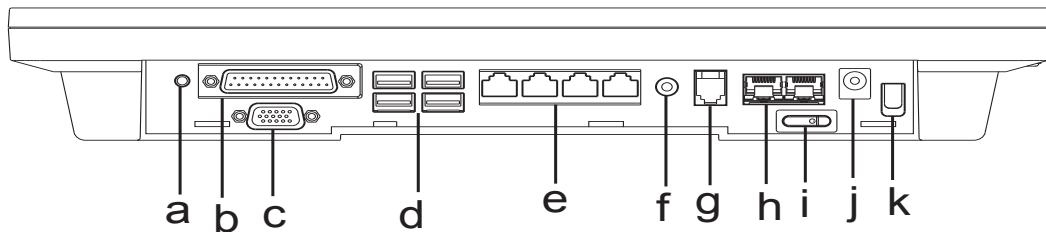

Item No.	Description
a	Power button
b	Parallel
c	VGA out
d	USB x 4
e	COM 1, 2, 3, 4 (from right to left)
f	Line-out
g	Cash drawer
h	LAN x 2
i	Power switch
j	DC-IN
k	Cable strap

2-4. System Dimension

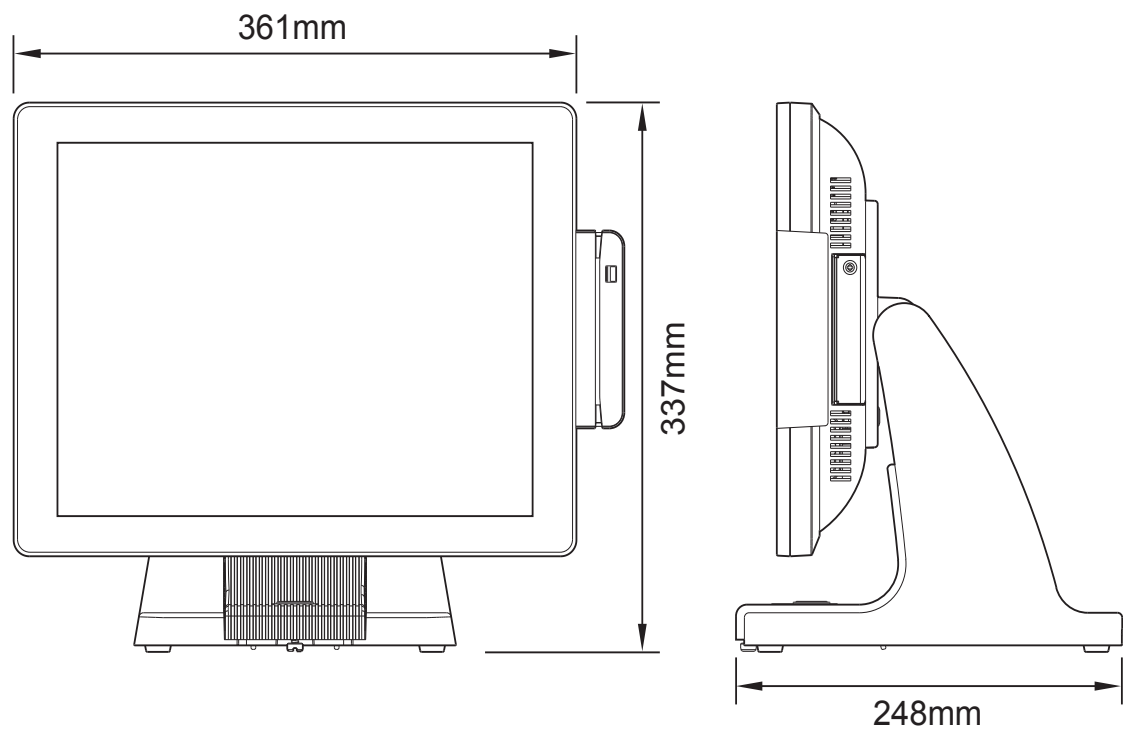

3. System Assembly & Disassembly

3-1. Stand Disassembly

1. Loosen the thumb screw (x1) and slide the stand towards the IO panel to release it from the system.
2. Reverse the steps above to attach stand to the system.

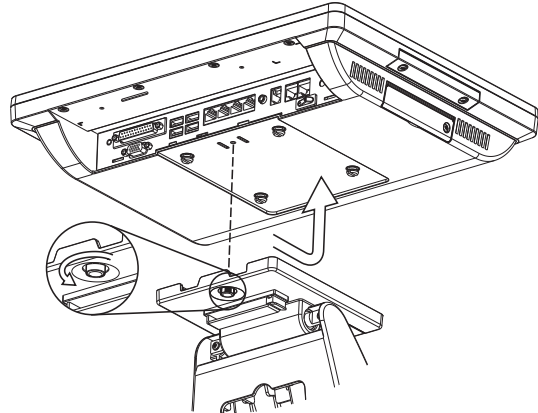

3-2. Power Adapter Replacement

Power adapter is secured to the system stand by a holding bracket and screws. To attach power adapter, please follow the steps below.

1. Route the cable as shown in the picture.
2. Connect the cable to the DC-IN port on system IO panel.

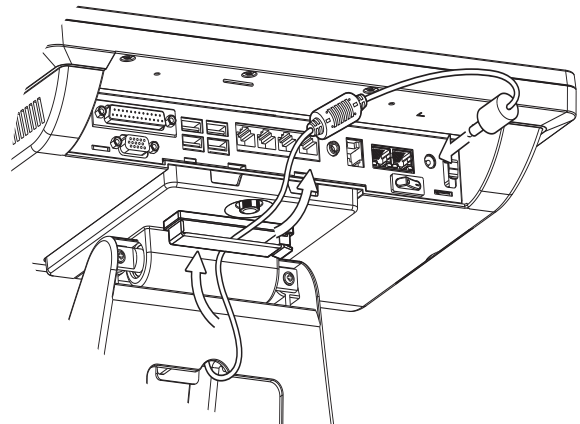

3-3. HD Replacement

Please remove the current HDD first.

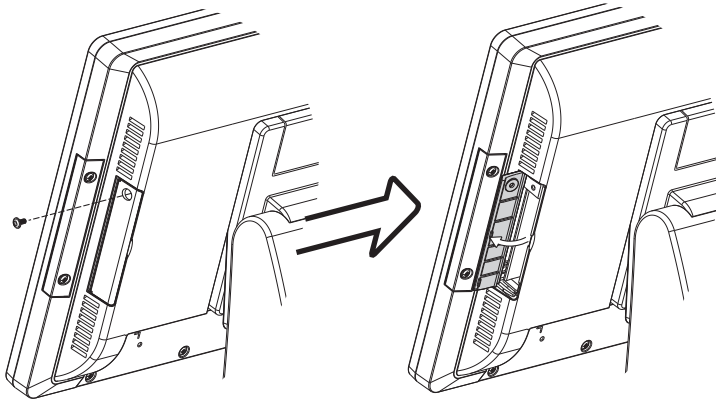

To remove the HDD from the System

1. Power the system down.
2. Remove the screw(x1) from the HDD door.
3. Open the HDD door.
4. While pinching the HDD bracket tabs pull the HDD from the system. For easier removal pull the plastic puller (see picture) at the same time.

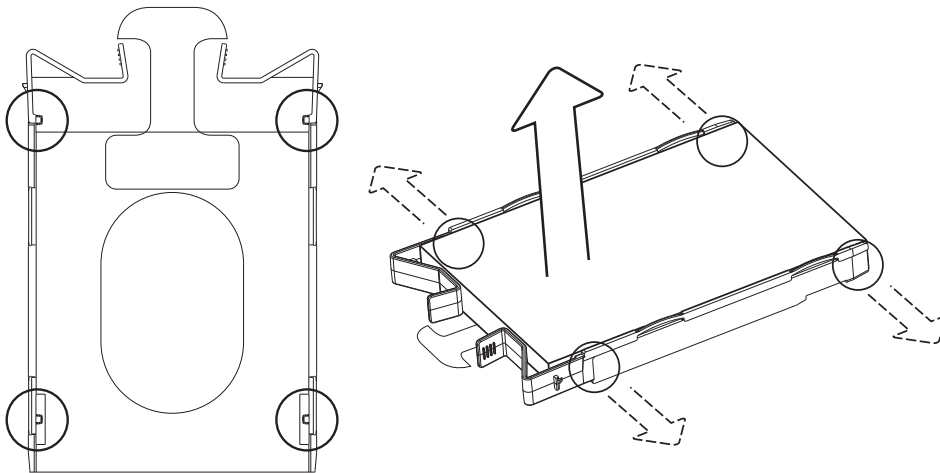
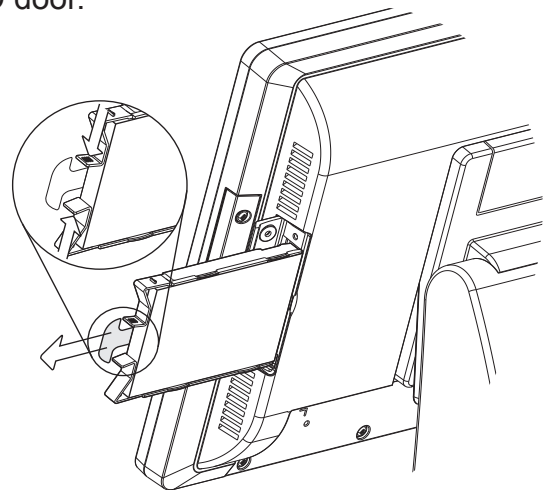

Disassemble HDD

5. To release the HDD from the bracket gently pull it open until the four pins are removed.

6. To install a new HDD. Attach the HDD to the bracket until it clicks in place. Make sure to press the edges of the drive not the center to avoid damaging the drive.

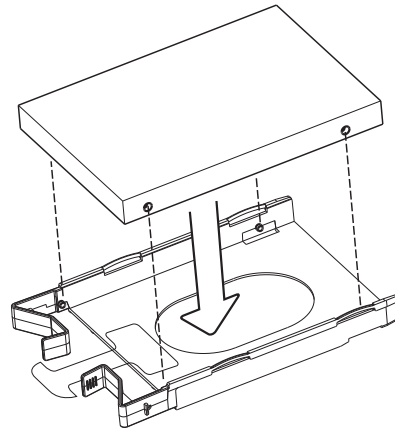

7. Finally slide the HDD into the slot till it clicks.

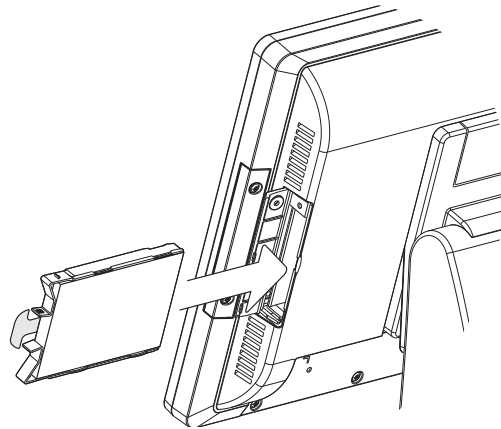

3-4. Open the System

1. Place the system face down. Making sure not to scratch the screen.
2. Remove the screws (x4) on system rear cover to open the system.

note: If the system is equipped with a MSR. The MSR must be removed first.(refer to Chapter 4-1 and reverse the steps to remove the MSR)

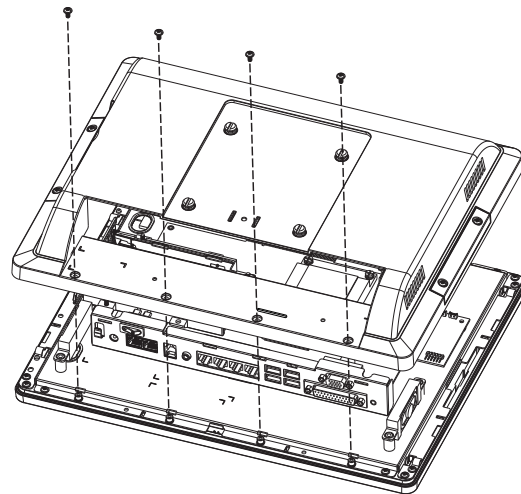

3-5. RAM Replacement

1. Follow the steps in Chapter 3-4 to open the system.
2. The RAM is located on the right side of the system (see picture).

Installing a RAM module

3. Slide the memory module into the memory slot and press down until it locks in place.

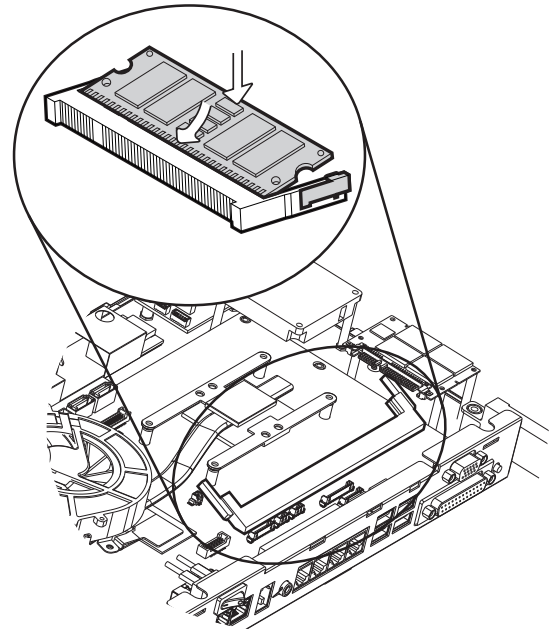

Removing a RAM module

3. To remove the module pull the ejector clips out of the side of the module.
4. Slide the memory out of the slot.

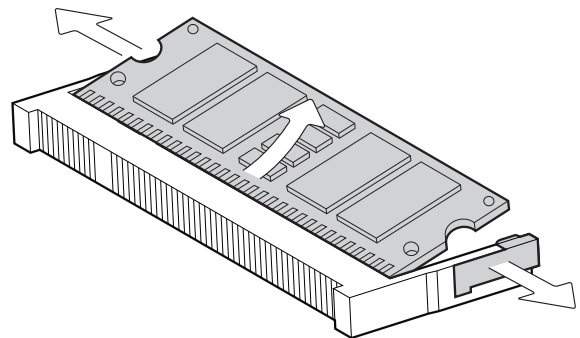

4. Peripheral Installation

4-1. MSR Installation

MSR module can be installed to either side of the system. Choose one side and follow the steps below. Make sure the unit is powered down before starting.

1. Remove the screws (x2) to release the MSR dummy cover.

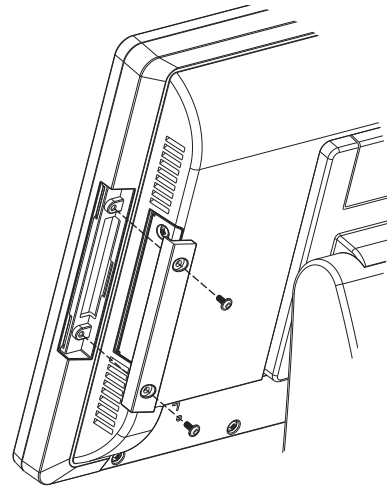

2. Connect MSR cable to the connector on system side.
3. Insert MSR module in place and fasten the screws (x2) on the back to secure the module.

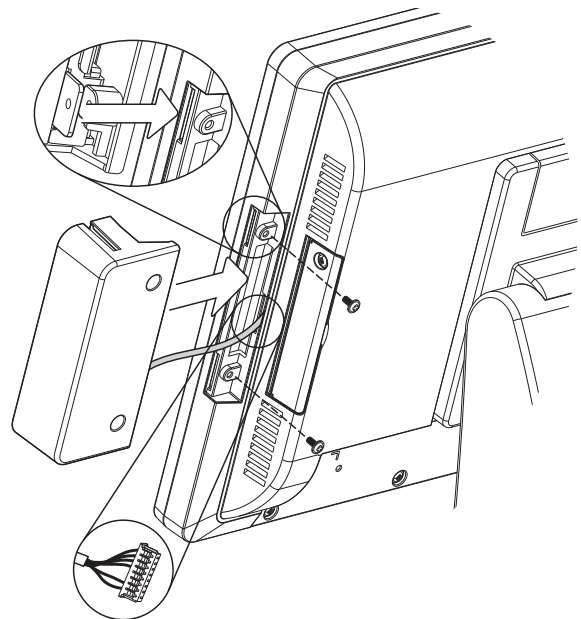

4-2. VFD Installation

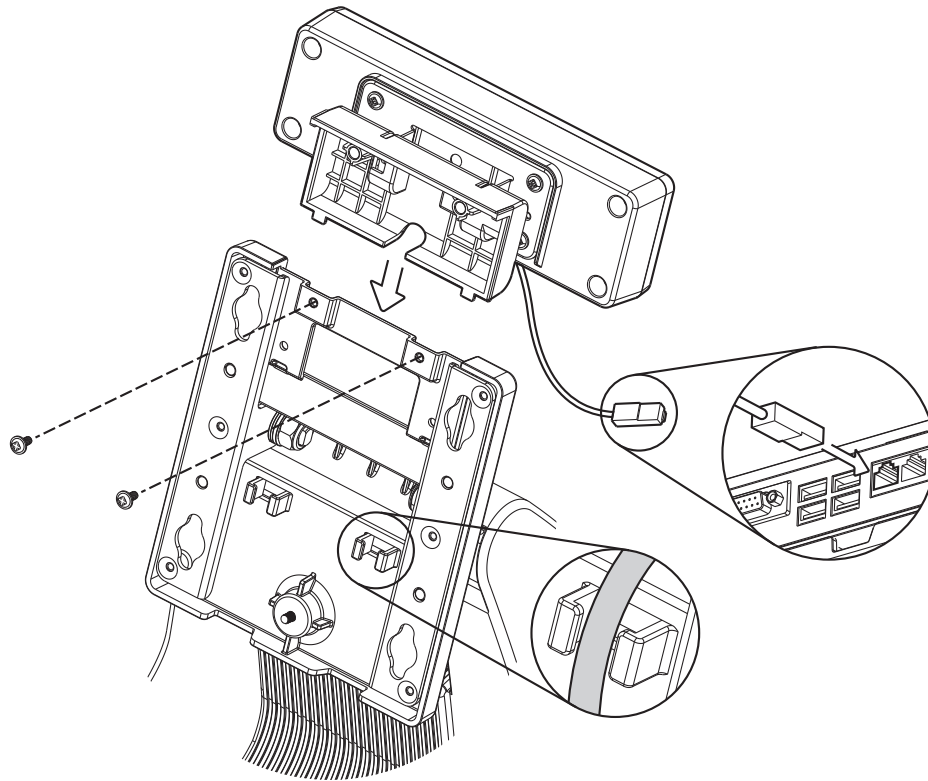

1. Follow steps in Chapter 3-1 to disassemble the system stand.
2. Attach the VFD module to system by fastening the screws (x2).
3. Route the cable through cable mangement on the system stand.
4. Connect the RJ-45 cable to COM 4 on the systems IO panel. Make sure the system is powered off.

4-3. Second Display Installation

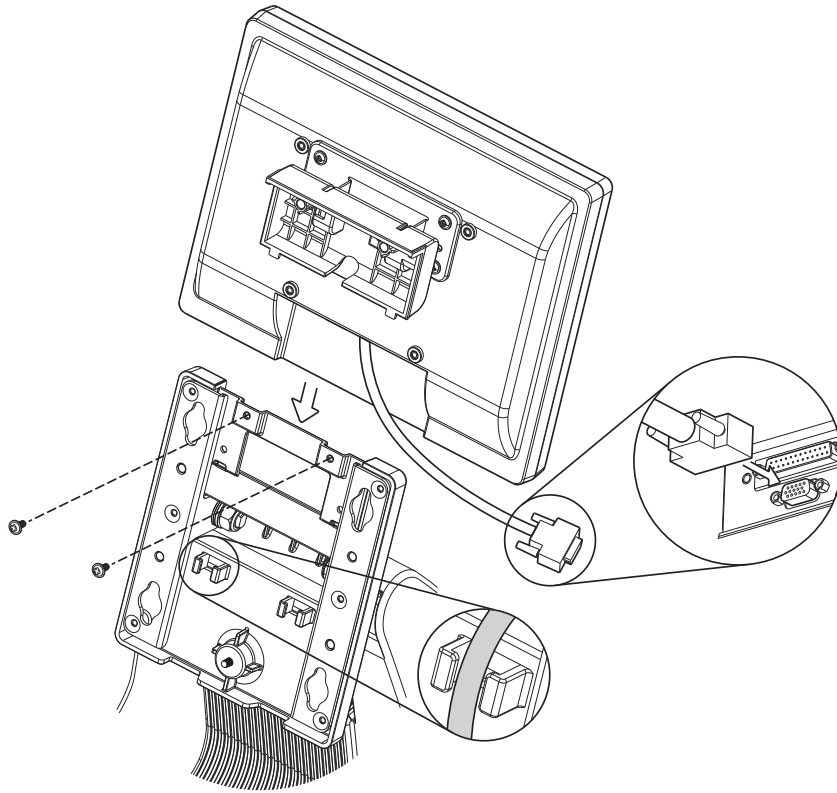

1. Follow steps in Chapter 3-1 to disassemble the system stand.
2. Connect one end of the VGA cable to 2nd Display. Route the cable through cable mangement on the system stand.
3. Attach the 2nd Display to system by fastening the screws (x2).
4. Connect the other end of the VGA cable to 2nd VGA port on system IO panel. Make sure the system is powered off.

4-4. Wall Mounting Kit Installation

The Wall mounting Kit includes a wall plate, a metal bracket, and one screw. (refer to Chapter 1-2 item d) Please follow the steps below.

1. Secure the wall plate to the wall by fastening screws (x4).

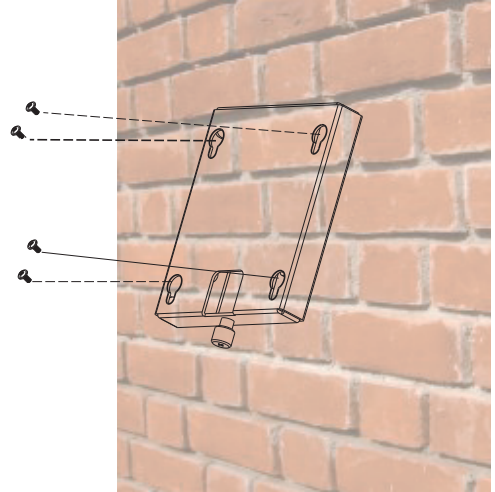

2. Attach the metal bracket to the back of the system by fastening the screw (x1) as shown.

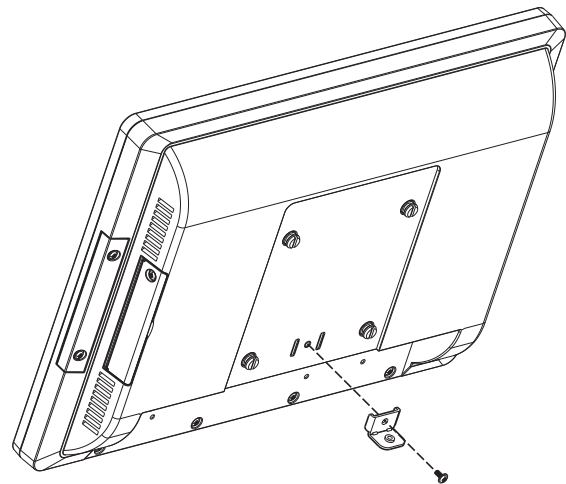

3. Align the large end of the teardrop mounting holes (x4) on the wall plate with the screws (x4) on the systems rear cover. Slide the wall plate until the screws are even with the narrow end.

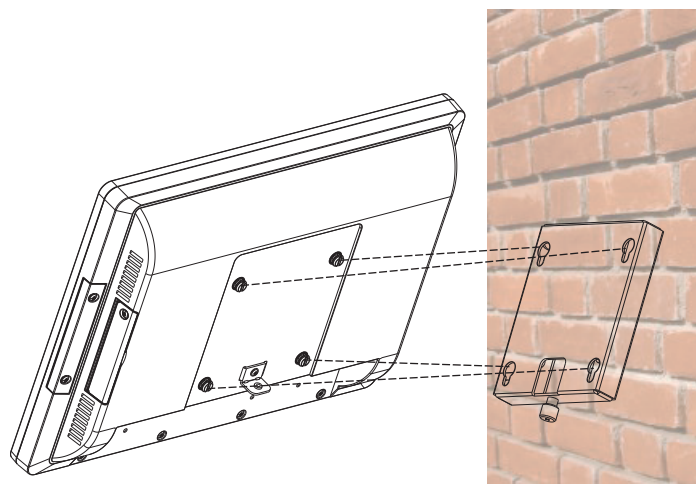

4. Fasten the screw (x1) through the metal bracket to secure the wall mount kit.

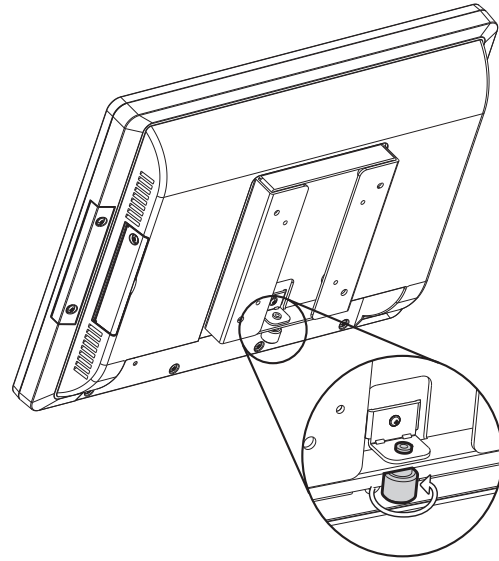

4-5. Cable Cover Installation

There are two different cable covers. These can be utilized separately or together. When both are needed, please take care that they are installed in the correct order.

1. Slide the covers on the IO panel, if using both covers the large cover needs to be installed before the smaller one.
2. Fasten the screws (x3, two for the larger one and one for the smaller one) to secure the covers.

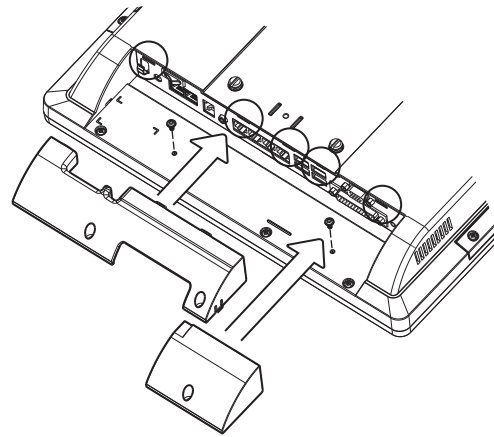

4-6. Cash Drawer Installation

You can install a cash drawer through the cash drawer port. Please verify the pin assignment before installation.

Cash Drawer Pin Assignment

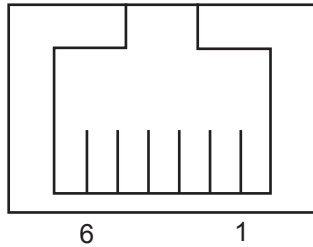

Pin	Signal
1	GND
2	DOUT bit0
3	DIN bit0
4	12V / 19V
5	DOUT bit1
6	GND

Cash Drawer Controller Register

The Cash Drawer Controller use one I/O addresses to control the Cash Drawer.

Register Location: 48Ch

Attribute: Read / Write

Size: 8bit

BIT	BIT7	BIT6	BIT5	BIT4	BIT3	BIT2	BIT1	BIT0
Attribute	Reserved	Read	Reserved		Write		Reserved	

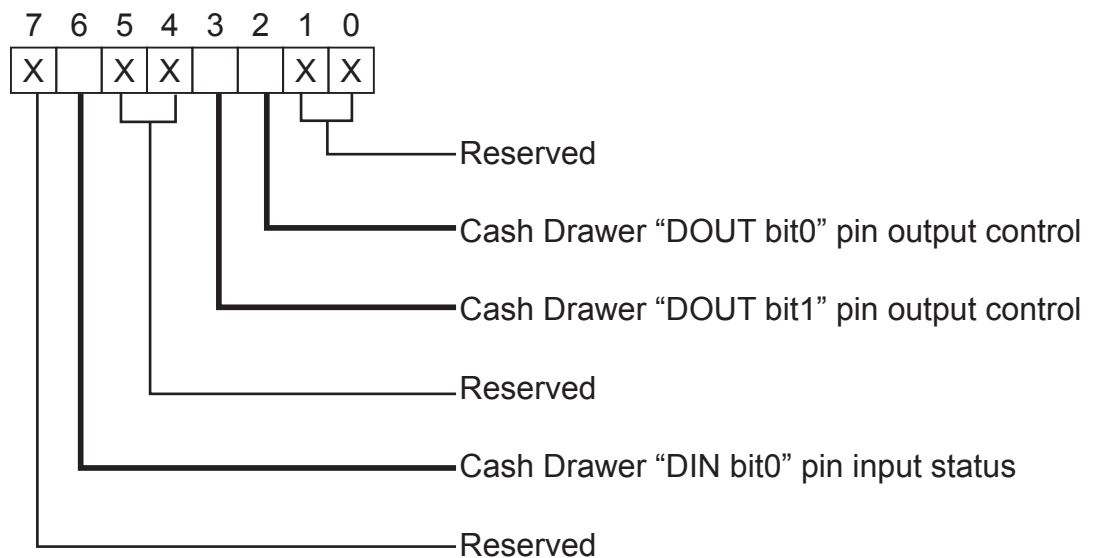

- Bit 7: Reserved
- Bit 6: Cash Drawer "DIN bit0" pin input status.
 - = 1: the Cash Drawer closed or no Cash Drawer
 - = 0: the Cash Drawer opened
- Bit 5: Reserved
- Bit 4: Reserved
- Bit 3: Cash Drawer "DOUT bit1" pin output control.
 - = 1: Opening the Cash Drawer
 - = 0: Allow close the Cash Drawer
- Bit 2: Cash Drawer "DOUT bit0" pin output control.
 - = 1: Opening the Cash Drawer
 - = 0: Allow close the Cash Drawer
- Bit 1: Reserved
- Bit 0: Reserved

Note: Please follow the Cash Drawer control signal design to control the Cash Drawer.

Cash Drawer Control Command Example

Use Debug.EXE program under DOS or Windows98

Command	Cash Drawer
O 48C 04	Opening
O 48C 00	Allow to close
<ul style="list-style-type: none"> ▶ Set the I/O address 48Ch bit2 =1 for opening Cash Drawer by "DOUT bit0" pin control. ▶ Set the I/O address 48Ch bit2 = 0 for allow close Cash Drawer. 	

Command	Cash Drawer
I 48C	Check status
<ul style="list-style-type: none"> ▶ The I/O address 48Ch bit6 =1 mean the Cash Drawer is opened or not exist. ▶ The I/O address 48Ch bit6 =0 mean the Cash Drawer is closed. 	

5. Specifications

Model Name	EVO-TP4A / EVO-TP4C		
Motherboard	C48	B68	C68
CPU Support	Intel Pineview D525 1.8G L21M, dual core 13W	Intel Atom N270 processor 1.6GHz L2 512K	Intel Sandy Bridge CPU i3-2120 3.3G, L2 3M, 65W Pentium G850 2.9G, L2 3M, 65W Celeron G530 2.4G, L2 2M, 65W
Chipset	CPU with Graphic built-in+ ICH 8M	Intel 945GSE Express + ICH7M	Intel Q67 PCH (Processor Controller Hub, AMT supported_highend) Intel H61 PCH (Processor Controller Hub, no AMT suport_mainstream)
System Memory	2 x SO-DIMM slot up to 4GB DDR3 800MHz	2 x SO-DIMM slot up to 2GB DDR2 533MHz	1 x Long DIMM slot up to 8GB DDR3 1066/1333 MHz
Graphic Memory	Shared system memory up to 256MB	Shared system memory up to 224MB	Intel HD Graphics 3000/2000, integrated in CPU, frequency 850MHz, (dynamic up to 1.1GHz)
LCD Touch Panel			
LCD Size	15" TFT LCD		
Brightness	250nits		
Maximal Resolution	1024 x 768		
Touch Screen Type	Resistive		
Tilt Angle	0° ~ 90°		
Storage			
HDD	One 2.5" SATA HDD bay		
Expansion			
PCI-E Socket	1		
External I/O Ports			
USB	4 ports (V2.0)		
Serial / COM	4 x RJ45 COM (COM1~COM3 standard RS-232 without power, COM4 +12V enable/disable by BIOS setting)	4 x RJ45 COM (COM1~COM3 standard RS-232; COM4 pin9 with 12V power by jumper)	4 x RJ45 COM (COM1~COM3 standard RS-232 without power, COM4 +12V enable/disable by BIOS setting)
Parallel	1		
LAN (10/100/1000)	1 x RJ45		2 x RJ45
DC Jack	1		
2nd VGA	1 (Female)		
Cash Drawer Port	1 x RJ 11 (12V /24V)		1 x RJ 11 (12V /24V)
Audio Jack	1 x Line-out, 1 x Mic-in		1 x Line-out
Audio			
Built in Speaker	2 x 2W speakers		
Power			
Power Adapter	19V / 90W		19V / 120W
Control / Indicator			
Power Button	1		
Indicator LED	1		
Peripheral			
MSR	3 Tracks MSR (PS/2)		
Bio Reader	1 (USB)		
Second Display	(optional) 8.4" / 15" 2nd display without touch		
Customer Display	Flush mount VFD display 2 x 20 characters (COM)		
Environment			
EMC & Safety	FCC, Class A, CE, LVD		
Operating Temperature	5°C ~ 35°C (41°F ~ 95°F)		
Storage Temperature	-20°C ~ 55°C (-4°F ~ 140°F)		
Operating Humidity	20% ~ 80% RH non condensing		
Storage Humidity	20% ~ 85% RH non condensing		

Dimension (WxDxH)	LCD 90 degree : 361 x 248 x 337 mm	
Weight (N.W./G.W.)	7kgs / 8kgs	
Mounting	100mm x100mm VESA mounting holes for Panel PC type	
OS Support	Windows® XP Professional, Windows Embedded POSReady 2009, Windows XP Embedded, Windows XP Professional for Embedded, WinCE, Vista, Windows 7, Linux	Windows® XP Professional, Windows Embedded POSReady 2009, Windows XP Embedded, Windows XP Professional for Embedded, POSready 7, Vista, Windows 7, Linux

* This specification is subject to change without prior notice.

6. Jumper Setting

6-1. C48 Motherboard

6-1-1. Motherboard Layout

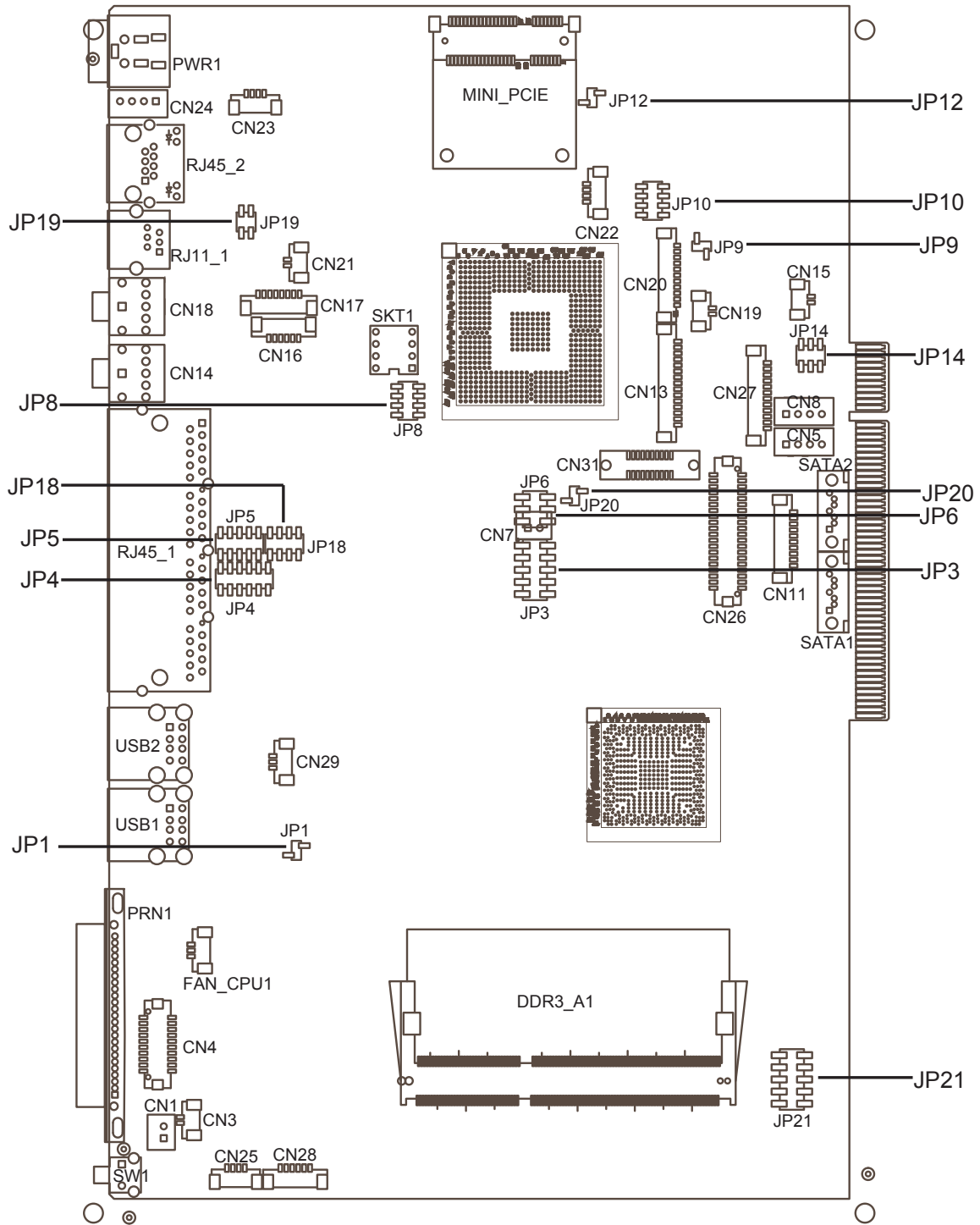

C48 V2.1 TOP LAYER

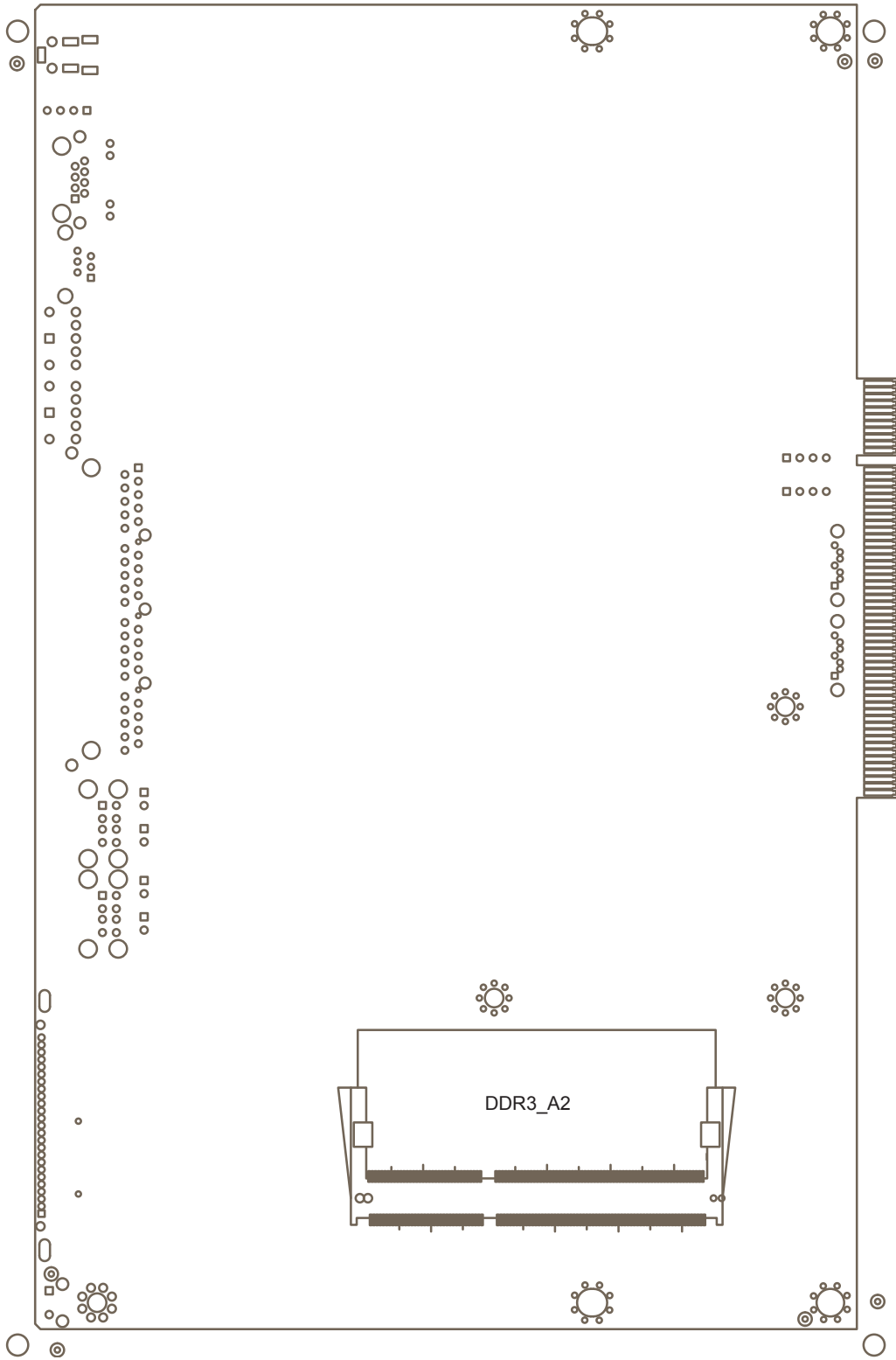

C48 V2.1 BOTTOM LAYER

6-1-2. Connectors & Functions

Connector	Purpose
CN1	Power Button Connector
CN3	Printer Port Reset
CN4	Printer Port
CN5/8	HDD Power
CN11	COM5 For Touch
CN13	Card Reader Connector
CN14	Line out
CN15	HDD LED
CN16	Speaker & MIC
CN18	MIC IN
CN20/JP10	System Indicator
CN22	USB Port
CN23	PS2 KEYBOARD
CN26	LVDS
CN27	Inverter Connector
CN29	System Fan
DDR3_A1	DDR3 SO-DIMM1
DDR3_A2	DDR3 SO-DIMM2
PRN1	Parallel Port
PWR1	+19V DC Jack
RJ11_1	Cash Drawer Connector
RJ45_1	COM1, COM2, COM3, COM4
RJ45_2	LAN
SATA1	SATA Connector
SATA2	SATA Connector
USB1	USB1, USB2
USB2	USB3, USB4
SW1	Power Button
JP1	CMOS Operation Mode
JP3/6	VGA Port
JP4/5	COM2 RS232/485/422 Setting
JP8	LCD ID Setting
JP12	System Reset
JP14	Inverter Selection
JP18	COM3/4 Power Setting
JP19	Cash Drawer Power Setting

6-1-3. Jumper & BIOS/Utility Setting

COM2 RS232/485/422 Setting

Function	JP5	JP4																						
▲RS232	<table border="1"> <tr> <td>1</td> <td>3</td> <td>5</td> <td>7</td> <td>9</td> </tr> <tr> <td>2</td> <td>4</td> <td>6</td> <td>8</td> <td>10</td> </tr> </table>	1	3	5	7	9	2	4	6	8	10	<table border="1"> <tr> <td>1</td> <td>3</td> <td>5</td> <td>7</td> <td>9</td> <td>11</td> </tr> <tr> <td>2</td> <td>4</td> <td>6</td> <td>8</td> <td>10</td> <td>12</td> </tr> </table>	1	3	5	7	9	11	2	4	6	8	10	12
1	3	5	7	9																				
2	4	6	8	10																				
1	3	5	7	9	11																			
2	4	6	8	10	12																			
RS485	<table border="1"> <tr> <td>1</td> <td>3</td> <td>5</td> <td>7</td> <td>9</td> </tr> <tr> <td>2</td> <td>4</td> <td>6</td> <td>8</td> <td>10</td> </tr> </table>	1	3	5	7	9	2	4	6	8	10	<table border="1"> <tr> <td>1</td> <td>3</td> <td>5</td> <td>7</td> <td>9</td> <td>11</td> </tr> <tr> <td>2</td> <td>4</td> <td>6</td> <td>8</td> <td>10</td> <td>12</td> </tr> </table>	1	3	5	7	9	11	2	4	6	8	10	12
1	3	5	7	9																				
2	4	6	8	10																				
1	3	5	7	9	11																			
2	4	6	8	10	12																			
RS422	<table border="1"> <tr> <td>1</td> <td>3</td> <td>5</td> <td>7</td> <td>9</td> </tr> <tr> <td>2</td> <td>4</td> <td>6</td> <td>8</td> <td>10</td> </tr> </table>	1	3	5	7	9	2	4	6	8	10	<table border="1"> <tr> <td>1</td> <td>3</td> <td>5</td> <td>7</td> <td>9</td> <td>11</td> </tr> <tr> <td>2</td> <td>4</td> <td>6</td> <td>8</td> <td>10</td> <td>12</td> </tr> </table>	1	3	5	7	9	11	2	4	6	8	10	12
1	3	5	7	9																				
2	4	6	8	10																				
1	3	5	7	9	11																			
2	4	6	8	10	12																			

Cash Drawer Power Setting

Function	JP19				
+19V	<table border="1"> <tr> <td>1</td> <td>3</td> </tr> <tr> <td>2</td> <td>4</td> </tr> </table>	1	3	2	4
1	3				
2	4				
▲+12V	<table border="1"> <tr> <td>1</td> <td>3</td> </tr> <tr> <td>2</td> <td>4</td> </tr> </table>	1	3	2	4
1	3				
2	4				

System Reset

Function	JP12		
▲System Normal	<table border="1"> <tr> <td>1</td> </tr> <tr> <td>2</td> </tr> </table>	1	2
1			
2			
System Reset	<table border="1"> <tr> <td>1</td> </tr> <tr> <td>2</td> </tr> </table>	1	2
1			
2			

▲ = Manufacturer Default Setting

System Indicator

Function	JP10								
▲ Disable	<table border="1"> <tr> <td>1</td> <td>3</td> <td>5</td> <td>7</td> </tr> <tr> <td>2</td> <td>4</td> <td>6</td> <td>8</td> </tr> </table>	1	3	5	7	2	4	6	8
1	3	5	7						
2	4	6	8						
Enable	<table border="1"> <tr> <td>1</td> <td>3</td> <td>5</td> <td>7</td> </tr> <tr> <td>2</td> <td>4</td> <td>6</td> <td>8</td> </tr> </table>	1	3	5	7	2	4	6	8
1	3	5	7						
2	4	6	8						

Inverter Selection

Function	JP14						
▲ CCFL	<table border="1"> <tr> <td>1</td> <td>3</td> <td>5</td> </tr> <tr> <td>2</td> <td>4</td> <td>6</td> </tr> </table>	1	3	5	2	4	6
1	3	5					
2	4	6					
LED	<table border="1"> <tr> <td>1</td> <td>3</td> <td>5</td> </tr> <tr> <td>2</td> <td>4</td> <td>6</td> </tr> </table>	1	3	5	2	4	6
1	3	5					
2	4	6					

CMOS Operation Mode

CMOS Reset

To clear the CMOS,

1. Remove the power cable from the system.
2. Open the system, and set the 'CMOS Operation jumper' from 'CMOS Normal' to 'CMOS Reset'. (refer to the jumper shown below)
3. Connect the power cable to the system, and **power on the system**:
 in ATX mode: press the power button and it will fail power on
 in AT mode: turn on system power
4. Remove the power cable from the system.
5. Return the "CMOS Operation mode" jumper setting from "CMOS Reset" to "CMOS normal".
6. Connect the power cable and power on the system.

Function	JP1		
▲ CMOS Normal	<table border="1"> <tr> <td>1</td> </tr> <tr> <td>2</td> </tr> </table>	1	2
1			
2			
CMOS Reset	<table border="1"> <tr> <td>1</td> </tr> <tr> <td>2</td> </tr> </table>	1	2
1			
2			

▲ = Manufacturer Default Setting

COM3 & COM4 Power Setting

For C48, COM3/COM4 power adjustment must be made by BIOS/Utility and Jumper. Since COM3/COM4 default is "None" meaning no power, power must be on through BIOS prior to physical jumper change.

BIOS/Utility setup

1. Press key to enter BIOS SETUP UTILITY when system boot up.
2. Find tab "Advanced".
3. Select "Power Configuration COM/VGA Ports" and press <Enter> to go to sub screen.

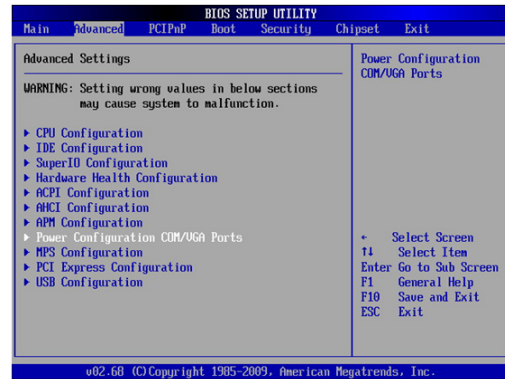

4. To switch on the power, select "Power". Please save the change before exiting BIOS so as to go for physical jumper adjustment.



Jumper Setup

Function		JP18								
COM3	▲ +5V	<table border="1"> <tr><td>1</td><td>3</td><td>5</td><td>7</td></tr> <tr><td>2</td><td>4</td><td>6</td><td>8</td></tr> </table>	1	3	5	7	2	4	6	8
	1	3	5	7						
2	4	6	8							
+12V	<table border="1"> <tr><td>1</td><td>3</td><td>5</td><td>7</td></tr> <tr><td>2</td><td>4</td><td>6</td><td>8</td></tr> </table>	1	3	5	7	2	4	6	8	
1	3	5	7							
2	4	6	8							
COM4	+5V	<table border="1"> <tr><td>1</td><td>3</td><td>5</td><td>7</td></tr> <tr><td>2</td><td>4</td><td>6</td><td>8</td></tr> </table>	1	3	5	7	2	4	6	8
	1	3	5	7						
2	4	6	8							
▲ +12V	<table border="1"> <tr><td>1</td><td>3</td><td>5</td><td>7</td></tr> <tr><td>2</td><td>4</td><td>6</td><td>8</td></tr> </table>	1	3	5	7	2	4	6	8	
1	3	5	7							
2	4	6	8							

▲ = Manufacturer Default Setting

LCD ID Setting

Several configurations are applied to different sizes of panel. Please refer to the followings to complete relevant settings.

• Jumper Setup

Resolution	LVDS		Output Interface	JP8
	Bits	Channel		
800 x 600	24	Single	1st: LCD Panel 2nd: VGA port	1 3 5 7 2 4 6 8
1024 x 768	24	Single		1 3 5 7 2 4 6 8
1366 x 768	24	Single		1 3 5 7 2 4 6 8
800 x 600	18	Single		1 3 5 7 2 4 6 8
*800 x 600	18	Single		1 3 5 7 2 4 6 8
1024 x 768	18	Single		1 3 5 7 2 4 6 8

*remark: specialized for Sharp 12.1" LQ121S1LG41/LQ121S1LG42 panel.

1 Jumper open 1 Jumper short
2 Jumper open 2 Jumper short

• 2nd VGA Power Setting

VGA port power must be on through BIOS/Utility for default is "No Power".

BIOS/Utility setup

1. Press key to enter BIOS SETUP UTILITY when system boot up.
2. Find tab "Advanced".
3. Select "Power Configuration COM/VGA Ports" and press <Enter> to go to sub screen.

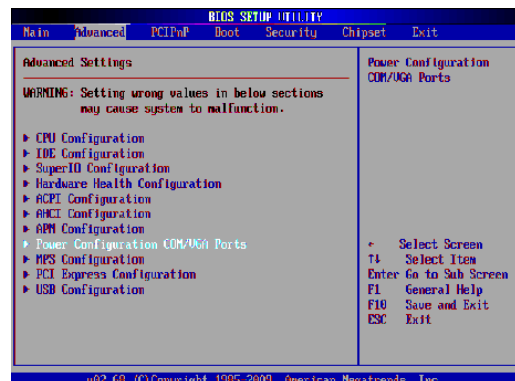

- To switch on the power, select "+12V". Please save the change before exiting BIOS to avoid data lost.



• Intel Graphics Driver Setting

- Right click Desktop. Select the "Graphics Properties" and enter the menu.



- Make sure the Display Device matches the image.

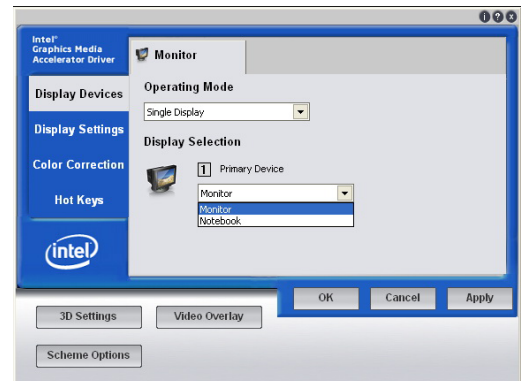

No.	Output Interface	Connector & Jumper	Intel Graphics Driver Device Name
1st	LCD Panel	CN26	Notebook
2nd	VGA Port	JP3/6	Monitor

6-2. B68 Motherboard

6-2-1. Motherboard Layout

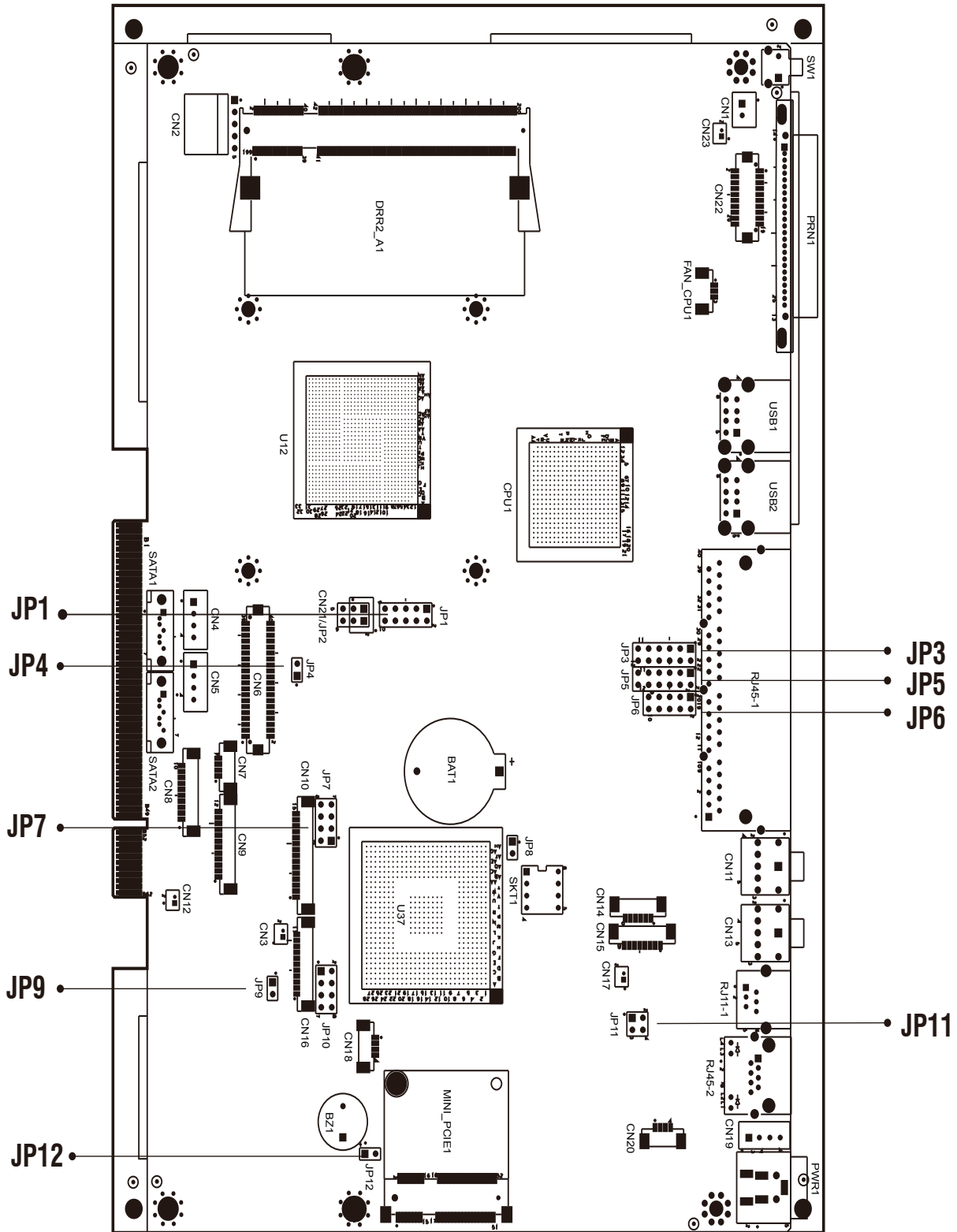

Version: B68 v1.1

6-2-2. Connectors & Functions

Connector	Purpose
BAT1	CMOS Battery Base (Use CR2023)
CN1	Power On Button
CN3	Power LED
CN4	SATA1 HDD Power Connector
CN5	SATA2 HDD Power Connector
CN6	LCD Interface Connector
CN8	For External Touch Connector
CN9	Inverter Connector
CN10	Card Reader Connector
CN12	LAN LED
CN14	Speaker & MIC Connector
CN15	CD-IN Connector
CN18	USB5
CN20	PS2 KEYBOARD
DDR2_A1	DDR2 SO-DIMM1
DDR2_A2	DDR2 SO-DIMM2
SATA1	SATA Connector
SATA2	SATA Connector
SW1	Power On Button
JP1	CRT Connector
JP3	Power Option for COM3/COM4
JP4	2nd Display Power
JP5/JP6	COM2 RS232/422/485 Setting
JP7	LCD ID Setting
JP11	Cash Drawer Power Setting
JP12	Hardware Reset

6-2-3. Jumper Setting

COM2 RS232/485/422 Setting

Function	JP6	JP5																						
▲RS232	<table border="1"> <tr><td>1</td><td>3</td><td>5</td><td>7</td><td>9</td></tr> <tr><td>2</td><td>4</td><td>6</td><td>8</td><td>10</td></tr> </table>	1	3	5	7	9	2	4	6	8	10	<table border="1"> <tr><td>1</td><td>3</td><td>5</td><td>7</td><td>9</td><td>11</td></tr> <tr><td>2</td><td>4</td><td>6</td><td>8</td><td>10</td><td>12</td></tr> </table>	1	3	5	7	9	11	2	4	6	8	10	12
1	3	5	7	9																				
2	4	6	8	10																				
1	3	5	7	9	11																			
2	4	6	8	10	12																			
RS485	<table border="1"> <tr><td>1</td><td>3</td><td>5</td><td>7</td><td>9</td></tr> <tr><td>2</td><td>4</td><td>6</td><td>8</td><td>10</td></tr> </table>	1	3	5	7	9	2	4	6	8	10	<table border="1"> <tr><td>1</td><td>3</td><td>5</td><td>7</td><td>9</td><td>11</td></tr> <tr><td>2</td><td>4</td><td>6</td><td>8</td><td>10</td><td>12</td></tr> </table>	1	3	5	7	9	11	2	4	6	8	10	12
1	3	5	7	9																				
2	4	6	8	10																				
1	3	5	7	9	11																			
2	4	6	8	10	12																			
RS422	<table border="1"> <tr><td>1</td><td>3</td><td>5</td><td>7</td><td>9</td></tr> <tr><td>2</td><td>4</td><td>6</td><td>8</td><td>10</td></tr> </table>	1	3	5	7	9	2	4	6	8	10	<table border="1"> <tr><td>1</td><td>3</td><td>5</td><td>7</td><td>9</td><td>11</td></tr> <tr><td>2</td><td>4</td><td>6</td><td>8</td><td>10</td><td>12</td></tr> </table>	1	3	5	7	9	11	2	4	6	8	10	12
1	3	5	7	9																				
2	4	6	8	10																				
1	3	5	7	9	11																			
2	4	6	8	10	12																			

COM3 & COM4 Power Setting

Function		JP3												
COM3 Pin10	▲RI	<table border="1"> <tr><td>1</td><td>3</td><td>5</td><td>7</td><td>9</td><td>11</td></tr> <tr><td>2</td><td>4</td><td>6</td><td>8</td><td>10</td><td>12</td></tr> </table>	1	3	5	7	9	11	2	4	6	8	10	12
	1	3	5	7	9	11								
	2	4	6	8	10	12								
+5V	<table border="1"> <tr><td>1</td><td>3</td><td>5</td><td>7</td><td>9</td><td>11</td></tr> <tr><td>2</td><td>4</td><td>6</td><td>8</td><td>10</td><td>12</td></tr> </table>	1	3	5	7	9	11	2	4	6	8	10	12	
1	3	5	7	9	11									
2	4	6	8	10	12									
+12V	<table border="1"> <tr><td>1</td><td>3</td><td>5</td><td>7</td><td>9</td><td>11</td></tr> <tr><td>2</td><td>4</td><td>6</td><td>8</td><td>10</td><td>12</td></tr> </table>	1	3	5	7	9	11	2	4	6	8	10	12	
1	3	5	7	9	11									
2	4	6	8	10	12									
COM4 Pin10	▲RI	<table border="1"> <tr><td>1</td><td>3</td><td>5</td><td>7</td><td>9</td><td>11</td></tr> <tr><td>2</td><td>4</td><td>6</td><td>8</td><td>10</td><td>12</td></tr> </table>	1	3	5	7	9	11	2	4	6	8	10	12
	1	3	5	7	9	11								
	2	4	6	8	10	12								
+5V	<table border="1"> <tr><td>1</td><td>3</td><td>5</td><td>7</td><td>9</td><td>11</td></tr> <tr><td>2</td><td>4</td><td>6</td><td>8</td><td>10</td><td>12</td></tr> </table>	1	3	5	7	9	11	2	4	6	8	10	12	
1	3	5	7	9	11									
2	4	6	8	10	12									
+12V	<table border="1"> <tr><td>1</td><td>3</td><td>5</td><td>7</td><td>9</td><td>11</td></tr> <tr><td>2</td><td>4</td><td>6</td><td>8</td><td>10</td><td>12</td></tr> </table>	1	3	5	7	9	11	2	4	6	8	10	12	
1	3	5	7	9	11									
2	4	6	8	10	12									

▲ = Manufacturer Default Setting

Cash Drawer Power Setting

Function	JP11				
+12V	<table border="1"> <tr> <td>1</td> <td>3</td> </tr> <tr> <td>2</td> <td>4</td> </tr> </table>	1	3	2	4
1	3				
2	4				
▲ +19V (for 24V Cash Drawer)	<table border="1"> <tr> <td>1</td> <td>3</td> </tr> <tr> <td>2</td> <td>4</td> </tr> </table>	1	3	2	4
1	3				
2	4				

VGA Power Setting

Function	JP4		
▲ No Power	<table border="1"> <tr> <td>1</td> </tr> <tr> <td>2</td> </tr> </table>	1	2
1			
2			
+12V	<table border="1"> <tr> <td>1</td> </tr> <tr> <td>2</td> </tr> </table>	1	2
1			
2			

System Reset

Function	JP12		
▲ System Normal	<table border="1"> <tr> <td>1</td> </tr> <tr> <td>2</td> </tr> </table>	1	2
1			
2			
System Reset	<table border="1"> <tr> <td>1</td> </tr> <tr> <td>2</td> </tr> </table>	1	2
1			
2			

▲ = Manufacturer Default Setting

LCD ID Setting

Panel#	Resolution	LVDS		Output Interface	JP7								
		Bits	Channel										
1	1366 x 768	24	Single	LVDS Panel	<table border="1"> <tr> <td>1</td> <td>3</td> <td>5</td> <td>7</td> </tr> <tr> <td>2</td> <td>4</td> <td>6</td> <td>8</td> </tr> </table>	1	3	5	7	2	4	6	8
1	3	5	7										
2	4	6	8										
2	1440 x 900	24	Dual	LVDS Panel	<table border="1"> <tr> <td>1</td> <td>3</td> <td>5</td> <td>7</td> </tr> <tr> <td>2</td> <td>4</td> <td>6</td> <td>8</td> </tr> </table>	1	3	5	7	2	4	6	8
1	3	5	7										
2	4	6	8										
4	1920 x 1080	24	Dual	LVDS Panel	<table border="1"> <tr> <td>1</td> <td>3</td> <td>5</td> <td>7</td> </tr> <tr> <td>2</td> <td>4</td> <td>6</td> <td>8</td> </tr> </table>	1	3	5	7	2	4	6	8
1	3	5	7										
2	4	6	8										
5	1024 x 768	24	Single	LVDS Panel	<table border="1"> <tr> <td>1</td> <td>3</td> <td>5</td> <td>7</td> </tr> <tr> <td>2</td> <td>4</td> <td>6</td> <td>8</td> </tr> </table>	1	3	5	7	2	4	6	8
1	3	5	7										
2	4	6	8										
6	1280 x 1024	24	Dual	LVDS Panel	<table border="1"> <tr> <td>1</td> <td>3</td> <td>5</td> <td>7</td> </tr> <tr> <td>2</td> <td>4</td> <td>6</td> <td>8</td> </tr> </table>	1	3	5	7	2	4	6	8
1	3	5	7										
2	4	6	8										
7	800 x 600	24	Single	LVDS Panel	<table border="1"> <tr> <td>1</td> <td>3</td> <td>5</td> <td>7</td> </tr> <tr> <td>2</td> <td>4</td> <td>6</td> <td>8</td> </tr> </table>	1	3	5	7	2	4	6	8
1	3	5	7										
2	4	6	8										
9	1024 x 768	18	Single	LVDS Panel	<table border="1"> <tr> <td>1</td> <td>3</td> <td>5</td> <td>7</td> </tr> <tr> <td>2</td> <td>4</td> <td>6</td> <td>8</td> </tr> </table>	1	3	5	7	2	4	6	8
1	3	5	7										
2	4	6	8										
11	800 x 600	18	Single	LVDS Panel	<table border="1"> <tr> <td>1</td> <td>3</td> <td>5</td> <td>7</td> </tr> <tr> <td>2</td> <td>4</td> <td>6</td> <td>8</td> </tr> </table>	1	3	5	7	2	4	6	8
1	3	5	7										
2	4	6	8										
12	800 x 600	18	Single	LVDS Panel	<table border="1"> <tr> <td>1</td> <td>3</td> <td>5</td> <td>7</td> </tr> <tr> <td>2</td> <td>4</td> <td>6</td> <td>8</td> </tr> </table>	1	3	5	7	2	4	6	8
1	3	5	7										
2	4	6	8										
				CRT	<table border="1"> <tr> <td>1</td> <td>3</td> <td>5</td> <td>7</td> </tr> <tr> <td>2</td> <td>4</td> <td>6</td> <td>8</td> </tr> </table>	1	3	5	7	2	4	6	8
1	3	5	7										
2	4	6	8										

Remark:

Panel ID#12 is specialized for Sharp 12.1" LQ121S1LG41/LQ121S1LG42 panel.

1
2

 Jumper open

1
2

 Jumper short

6-3. C68 Motherboard

6-3-1. Motherboard Layout

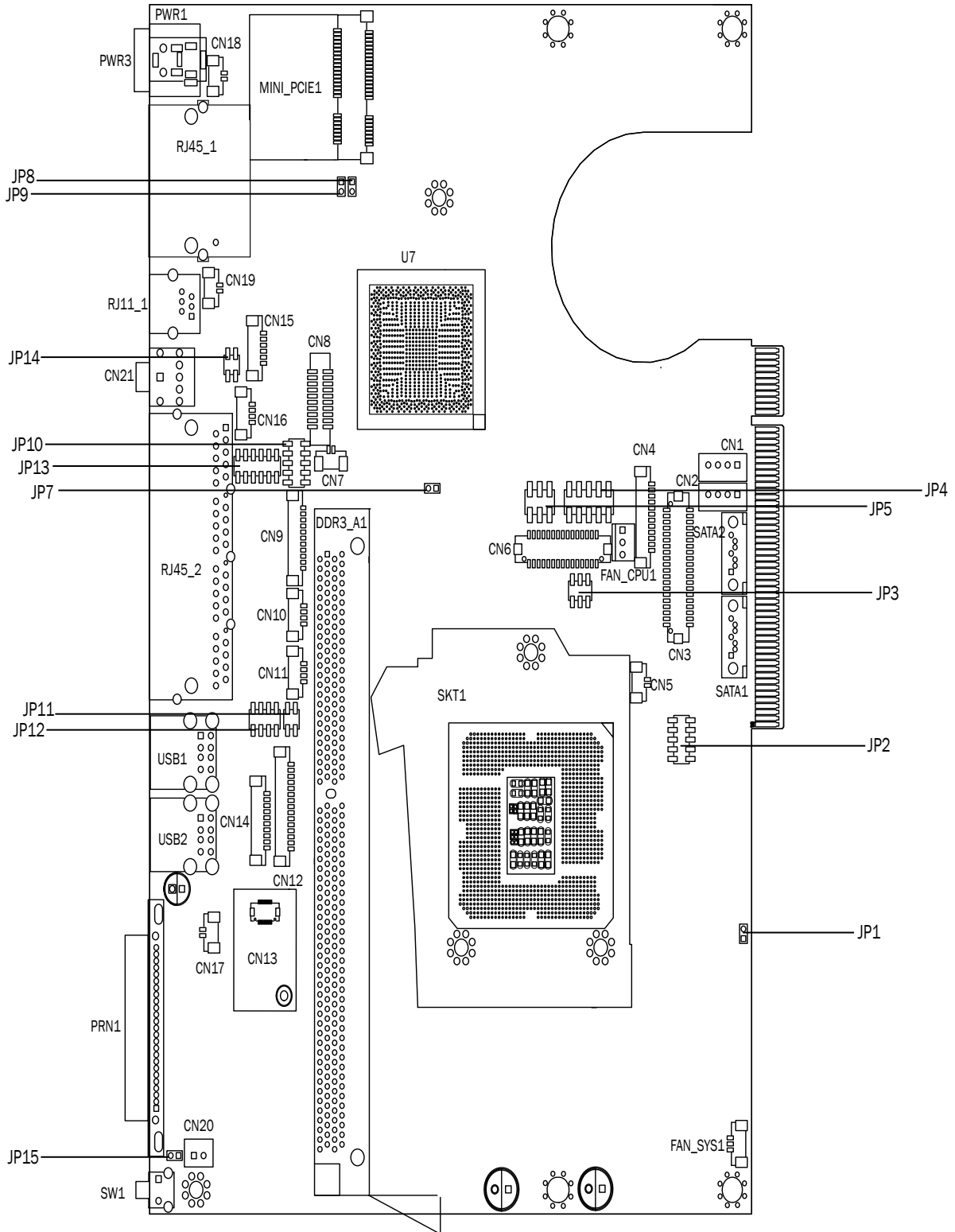

Version: C68 v1.0

6-3-2. Connectors & Functions

Connector	Purpose
CN1/2	SATA power Connector
CN3	LVDS Connector
CN4	LVDS INVERTER Connector
CN5	SATA HDD LED Connector
CN6	DVI Connector
CN7	BATTERY Connector
CN9	FT STATUS INTERFACE
CN10/11	USB Port(Internal)
CN12	Card Reader Connector(COM6)
CN13	RF Connector
CN14	COM5 for Touch
CN15	SPEAKER & MIC Connector (Internal)
CN16	PS2 Keyboard Connector
CN17	Power On LED Connector
CN18/CN19	LAN1/2 LED(Internal)
CN20	Power button(Internal)
CN21	Line out JACK
DDR3_A1	DDR3 LONG-DIMM
FAN_CPU1	CPU FAN Connector
FAN_SYS1	System FAN Connector
PRN1	PARALLEL PORT
PWR3	+19V DC JACK
RJ11_1	CASH DRAWER Connector
RJ45_1	LAN1/LAN2 Connector
RJ45_2	COM1/ COM2/ COM3/ COM4
SATA1/2	SATA Connector
USB1	USB4 USB2
USB2	USB3 USB4
JP2	LCD ID Setting
JP3	INVERTER Select
JP4/5	VGA
JP7	CMOS Operation Mode
JP8	ME Update
JP9	H/W Reset
JP10/13	COM2 RS232/485/422 Setting
JP11	USB Touch Power Setting(CN11)
JP12	COM3/COM4 Power Setting
JP14	CASH DRAWER Power Setting
SW1	Power button

6-3-3. Jumper Setting

Power Mode Setting

Function	JP1		
▲ ATX Power	<table border="1"> <tr><td>1</td></tr> <tr><td>2</td></tr> </table>	1	2
1			
2			
AT Power	<table border="1"> <tr><td>1</td></tr> <tr><td>2</td></tr> </table>	1	2
1			
2			

COM2 RS232/485/422 Setting

Function	JP10	JP13																						
▲ RS232	<table border="1"> <tr><td>1</td><td>3</td><td>5</td><td>7</td><td>9</td></tr> <tr><td>2</td><td>4</td><td>6</td><td>8</td><td>10</td></tr> </table>	1	3	5	7	9	2	4	6	8	10	<table border="1"> <tr><td>1</td><td>3</td><td>5</td><td>7</td><td>9</td><td>11</td></tr> <tr><td>2</td><td>4</td><td>6</td><td>8</td><td>10</td><td>12</td></tr> </table>	1	3	5	7	9	11	2	4	6	8	10	12
1	3	5	7	9																				
2	4	6	8	10																				
1	3	5	7	9	11																			
2	4	6	8	10	12																			
RS485	<table border="1"> <tr><td>1</td><td>3</td><td>5</td><td>7</td><td>9</td></tr> <tr><td>2</td><td>4</td><td>6</td><td>8</td><td>10</td></tr> </table>	1	3	5	7	9	2	4	6	8	10	<table border="1"> <tr><td>1</td><td>3</td><td>5</td><td>7</td><td>9</td><td>11</td></tr> <tr><td>2</td><td>4</td><td>6</td><td>8</td><td>10</td><td>12</td></tr> </table>	1	3	5	7	9	11	2	4	6	8	10	12
1	3	5	7	9																				
2	4	6	8	10																				
1	3	5	7	9	11																			
2	4	6	8	10	12																			
RS422	<table border="1"> <tr><td>1</td><td>3</td><td>5</td><td>7</td><td>9</td></tr> <tr><td>2</td><td>4</td><td>6</td><td>8</td><td>10</td></tr> </table>	1	3	5	7	9	2	4	6	8	10	<table border="1"> <tr><td>1</td><td>3</td><td>5</td><td>7</td><td>9</td><td>11</td></tr> <tr><td>2</td><td>4</td><td>6</td><td>8</td><td>10</td><td>12</td></tr> </table>	1	3	5	7	9	11	2	4	6	8	10	12
1	3	5	7	9																				
2	4	6	8	10																				
1	3	5	7	9	11																			
2	4	6	8	10	12																			

Cash Drawer Power Setting

Function	JP14				
▲ +19V	<table border="1"> <tr><td>1</td><td>3</td></tr> <tr><td>2</td><td>4</td></tr> </table>	1	3	2	4
1	3				
2	4				
+12V	<table border="1"> <tr><td>1</td><td>3</td></tr> <tr><td>2</td><td>4</td></tr> </table>	1	3	2	4
1	3				
2	4				

▲ = Manufacturer Default Setting

Inverter Selection

Function	JP3						
▲ CCFL	<table style="border-collapse: collapse; margin: auto;"> <tr> <td style="padding: 0 5px;">1</td> <td style="padding: 0 5px;">3</td> <td style="border: 1px solid black; padding: 2px;">5</td> </tr> <tr> <td style="padding: 0 5px;">2</td> <td style="padding: 0 5px;">4</td> <td style="border: 1px solid black; padding: 2px;">6</td> </tr> </table>	1	3	5	2	4	6
1	3	5					
2	4	6					
LED	<table style="border-collapse: collapse; margin: auto;"> <tr> <td style="border: 1px solid black; padding: 2px;">1</td> <td style="border: 1px solid black; padding: 2px;">3</td> <td style="padding: 0 5px;">5</td> </tr> <tr> <td style="border: 1px solid black; padding: 2px;">2</td> <td style="border: 1px solid black; padding: 2px;">4</td> <td style="padding: 0 5px;">6</td> </tr> </table>	1	3	5	2	4	6
1	3	5					
2	4	6					

ME Update

Function	JP8		
▲ Lock	<table style="border-collapse: collapse; margin: auto;"> <tr> <td style="border: 1px solid black; padding: 2px;">1</td> </tr> <tr> <td style="border: 1px solid black; padding: 2px;">2</td> </tr> </table>	1	2
1			
2			
Un-lock	<table style="border-collapse: collapse; margin: auto;"> <tr> <td style="border: 1px solid black; padding: 2px;">1</td> </tr> <tr> <td style="border: 1px solid black; padding: 2px;">2</td> </tr> </table>	1	2
1			
2			

Hardware Reset

Function	JP9		
▲ System Normal	<table style="border-collapse: collapse; margin: auto;"> <tr> <td style="border: 1px solid black; padding: 2px;">1</td> </tr> <tr> <td style="border: 1px solid black; padding: 2px;">2</td> </tr> </table>	1	2
1			
2			
System Reset	<table style="border-collapse: collapse; margin: auto;"> <tr> <td style="border: 1px solid black; padding: 2px;">1</td> </tr> <tr> <td style="border: 1px solid black; padding: 2px;">2</td> </tr> </table>	1	2
1			
2			

USB Touch Power Setting for CN11 Connector

Function	JP11				
▲ +5VSB	<table style="border-collapse: collapse; margin: auto;"> <tr> <td style="border: 1px solid black; padding: 2px;">1</td> <td style="padding: 0 5px;">3</td> </tr> <tr> <td style="border: 1px solid black; padding: 2px;">2</td> <td style="padding: 0 5px;">4</td> </tr> </table>	1	3	2	4
1	3				
2	4				
+5V	<table style="border-collapse: collapse; margin: auto;"> <tr> <td style="padding: 0 5px;">1</td> <td style="border: 1px solid black; padding: 2px;">3</td> </tr> <tr> <td style="padding: 0 5px;">2</td> <td style="border: 1px solid black; padding: 2px;">4</td> </tr> </table>	1	3	2	4
1	3				
2	4				

▲ = Manufacturer Default Setting

CMOS Operation Mode

CMOS Reset

To clear the CMOS,

1. Remove the power cable from the system.
2. Open the system, and set the 'CMOS Operation jumper' from 'CMOS Normal' to 'CMOS Reset'. (refer to the jumper shown below)
3. Connect the power cable to the system, and **power on the system**:
in ATX mode: press the power button and it will fail power on
in AT mode: turn on system power
4. Remove the power cable from the system.
5. Return the "CMOS Operation mode" jumper setting from "CMOS Reset" to "CMOS normal".
6. Connect the power cable and power on the system.

Function	JP7
▲ CMOS Normal	<div style="border: 1px solid black; padding: 2px; display: inline-block;"> 1 2 </div>
CMOS Reset	<div style="border: 1px solid black; padding: 2px; display: inline-block;"> 1 2 </div>

COM3 & COM4 Power Setting

COM3 and COM4 can be set to provide power to your serial device.

The voltage can be set to +5V or 12V by setting jumper JP18 on the motherboard. When enabled, the power is available on pin 10 of the RJ45 serial connector. If you use the serial RJ45 to DB9 adapter cable, the power is on pin 9 of the DB9 connector.

By default, the power option is disabled in the BIOS.

BIOS/Utility setup

1. Press key to enter BIOS SETUP UTILITY when system boot up.
2. Find tab "Advanced".
3. Select "Power Configuration COM/VGA Ports" and press <Enter> to go to sub screen.

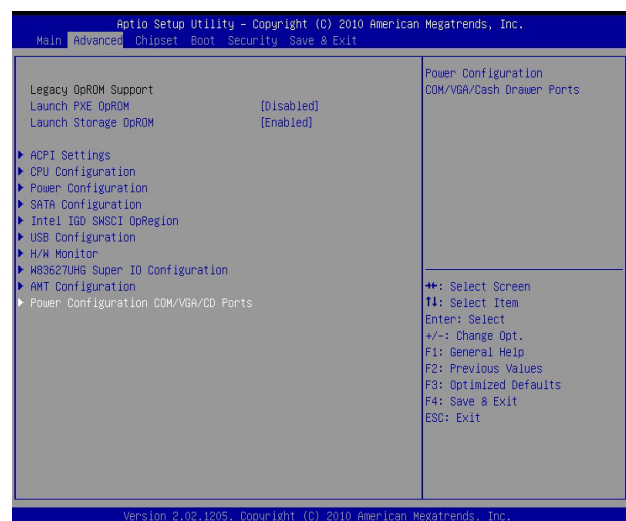

▲ = Manufacturer Default Setting

- To switch on the power, select "Power". Please save the change before exiting BIOS so as to go for physical jumper adjustment.

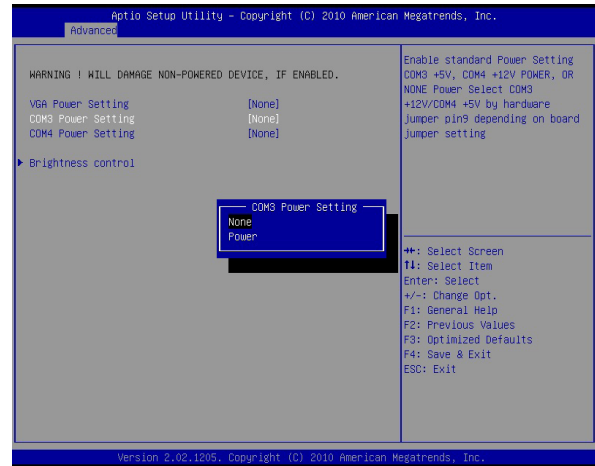

COM3/COM4 Jumper setup

Function		JP12								
COM3	▲ +5V	<table border="1"> <tr> <td>1</td> <td>3</td> <td>5</td> <td>7</td> </tr> <tr> <td>2</td> <td>4</td> <td>6</td> <td>8</td> </tr> </table>	1	3	5	7	2	4	6	8
	1	3	5	7						
2	4	6	8							
+12V	<table border="1"> <tr> <td>1</td> <td>3</td> <td>5</td> <td>7</td> </tr> <tr> <td>2</td> <td>4</td> <td>6</td> <td>8</td> </tr> </table>	1	3	5	7	2	4	6	8	
1	3	5	7							
2	4	6	8							
COM4	+5V	<table border="1"> <tr> <td>1</td> <td>3</td> <td>5</td> <td>7</td> </tr> <tr> <td>2</td> <td>4</td> <td>6</td> <td>8</td> </tr> </table>	1	3	5	7	2	4	6	8
	1	3	5	7						
2	4	6	8							
▲ +12V	<table border="1"> <tr> <td>1</td> <td>3</td> <td>5</td> <td>7</td> </tr> <tr> <td>2</td> <td>4</td> <td>6</td> <td>8</td> </tr> </table>	1	3	5	7	2	4	6	8	
1	3	5	7							
2	4	6	8							

LCD ID Setting

Panel#	Resolution	LVDS		Output Interface	JP7
		Bits	Channel		
1	800 x 600	18	Single	LVDS Panel	1 3 5 7 9 2 4 6 8 10
3	800 x 600	24	Single	LVDS Panel	1 3 5 7 9 2 4 6 8 10
5	1024 x 768	18	Single	LVDS Panel	1 3 5 7 9 2 4 6 8 10
7	1024 x 768	24	Single	LVDS Panel	1 3 5 7 9 2 4 6 8 10
9	1280 x 1024	24	Dual	LVDS Panel	1 3 5 7 9 2 4 6 8 10
11	1366 x 768	24	Single	LVDS Panel	1 3 5 7 9 2 4 6 8 10
13	1440 x 900	24	Dual	LVDS Panel	1 3 5 7 9 2 4 6 8 10
15	1920 x 1020	24	Dual	LVDS Panel	1 3 5 7 9 2 4 6 8 10
				CRT	1 3 5 7 9 2 4 6 8 10

Remark:

Panel ID#12 is specialized for Sharp 12.1" LQ121S1LG41/LQ121S1LG42 panel.

1 Jumper open
 1 Jumper short
2 Jumper open
 2 Jumper short

Appendix: Drivers Installation

The shipping package includes a Driver CD in which you can find every individual driver and utility that enables you to install the drivers on the system.

Please insert the Driver CD into the drive and double click on the “index.htm” to select the models. You can refer to the drivers installation guide for each driver in the “Driver/Manual List”.