

User's Manual

iX800

15" P4 Fanless POS

COPYRIGHT NOTICE

This document is copyrighted, © 2007. All rights are reserved. The manufacturer has the right to make improvements of the product described in this manual at any time without notice.

No part of this manual may be reproduced, copied, translated, or transmitted in any form or by any means without the prior written permission from the manufacturer. Information provided in this manual is intended to be accurate and reliable. However, The manufacturer assumes no responsibility for its use, nor for any infringements upon the rights of third parties, which may result from its use.

The material in this document is for product information only and is subject to change without notice. While reasonable efforts have been made in the preparation of this document to assure its accuracy, the manufacturer, assumes no liabilities resulting from errors or omissions in this document, or from the use of the information contained herein.

SAFETY AND WARRANTY

Read these safety instructions carefully !

1. Keep this user's manual for later reference.
2. Disconnect this equipment from any AC outlet before cleaning. Do not use liquid or spray detergents for cleaning. Use a damp cloth.
3. For pluggable equipment, the power outlet must be installed near the equipment and must be easily accessible.
4. Keep this equipment away from humidity.
5. Put this equipment on a reliable surface during installation. Dropping it or letting it fall could cause damage.
6. The openings on the enclosure are for air convection. Protect the equipment from overheating. **DO NOT COVER THE OPENINGS.**
7. Make sure the voltage of the power source is correct before connecting the equipment to the power outlet.
8. Position the power cord so that people cannot step on it. Do not place anything over the power cord.
9. All cautions and warnings on the equipment should be noted.
10. If the equipment is not used for a long time, disconnect it from the power source to avoid damage by transient over-voltage.
11. Never pour any liquid into an opening. This could cause fire or electrical shock.
12. Never open the equipment. For safety reasons, only qualified service personnel should open the equipment.
13. If any of the following situations arises, get the equipment checked by service personnel:
 - a. The power cord or plug is damaged.
 - b. Liquid has penetrated into the equipment.
 - c. The equipment has been exposed to moisture.
 - d. The equipment does not work well, or you cannot get it to work according to the users manual.
 - e. The equipment has been dropped and damaged.
 - f. The equipment has obvious signs of breakage.
14. **DO NOT LEAVE THIS EQUIPMENT IN AN UNCONTROLLED ENVIRONMENT WHERE THE STORAGE TEMPERATURE IS BELOW -20° C (-4°F) OR ABOVE 60° C (140° F). IT MAY DAMAGE THE EQUIPMENT.**

Table of Content

Chapter 1	1
Introduction	1
IX800 Introduction	1
A Quick Tour of IX800	2
IX800 Dimension	3
Rear I/O Panel.....	4
Packing List	4
Chapter 2	5
Hardware Installation and Upgrading	5
2.5" Hard Disk Drive Installation	5
MCR Parameter Modification	6
Cash Drawer Installation	6
Chapter 3	8
Software Installation and Setup	8
Driver Installation.....	8
Please follow this installation sequence.	8
Intel Chipset Driver Installation.....	8
VGA Driver Installation	10
852GM driver installation Windows 2000 & XP	10
Enable second LCD panel setting Windows 2000/Windows XP.	12
Audio Driver Installation.....	16
Audio Driver Installation for all Windows Operating Systems.....	16
ELO Touch Tools Installation	18
ELO Touch Tools Installation for Windows 2000 and XP	18
ELO Control Panel.....	21
TouchKit Tools Installation	24
TouchKit Tools Installation for Windows Operating Systems	24
TouchKit Control Panel.....	27
Wireless LAN Driver Installation for Windows Operating Systems (Optional)	28
Chapter 4	29
Specifications	29
IX800 Specifications	29
Motherboard Configuration.....	31
I/O board Configuration	41
Chapter 5	45
Troubleshooting	45

Power is on, but there is no Panel Display	45
Cannot Detect HDD	46
Touch Panel Does not Work.....	46
ELO Touch Panel Cannot Calibrate Correctly	46
PS/2 Keyboard is not Functioning Normally	46
MCR is not Functioning Properly	47
VFD Display is not Functioning Properly	47
LAN is not Functioning Properly	47
COM1, COM2, COM5 are not Functioning Properly	47
Cash Drawer Port is not Functioning Properly	48
USB Device is not Functioning Properly.....	48

Introduction

IX800 Introduction

IX800 is a high-end system of POS solution. The extensible, robust and Fanless design makes it a perfect solution for retail and hospitality market.

- **System:** A high speed processor capable of handling a high capacity of data efficiently.
- **Housing:** The solid quality aluminum housing dissipates the heat inside the system and makes it a perfect Fanless solution, additionally it also assures the compliance to EMI radiation testing.
- **Display:** The LCD display can be tilted at multiple angles for operator ease of use.
- **Extensibility:** It can be adapted for a variety of uses with the addition of any of the following options: Magnetic Card Reader, VFD/LCD customer display and Cash drawer, Biometric reader and a wide variety of USB devices (all available upon request)

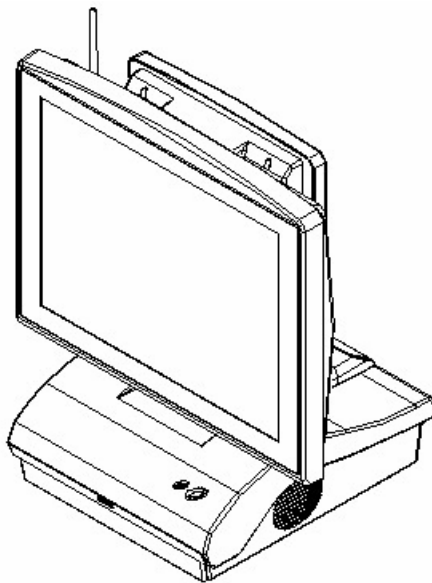

iX800 with VFD

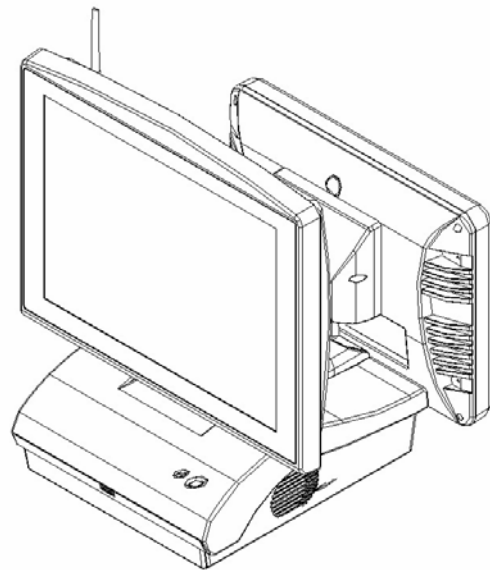

iX800 with 2nd Display

A Quick Tour of IX800

Before you start, take a moment to become familiar with IX800.

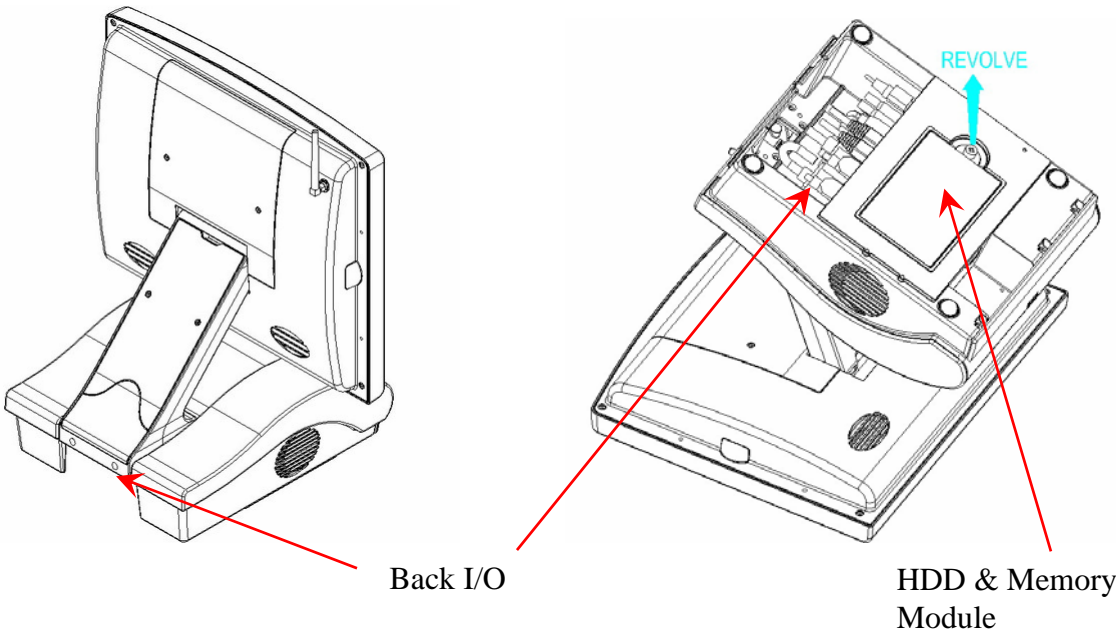
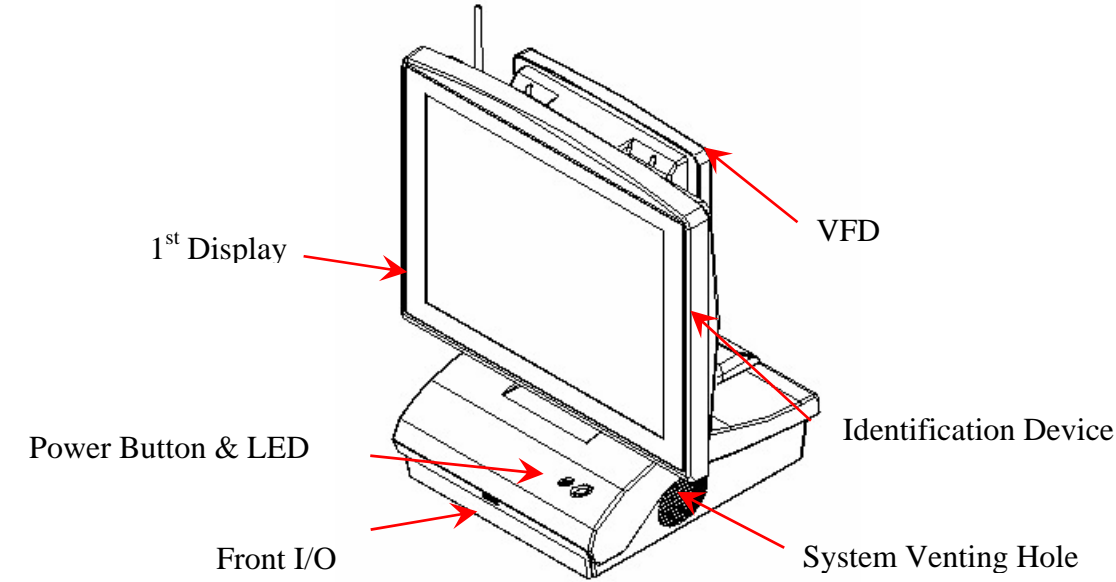

IX800 Dimension

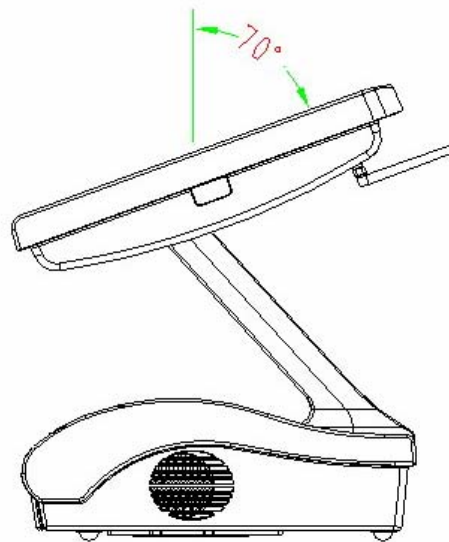
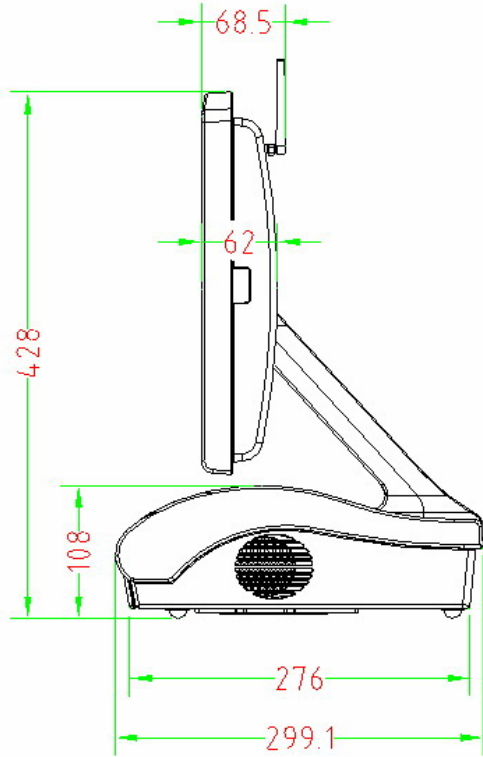
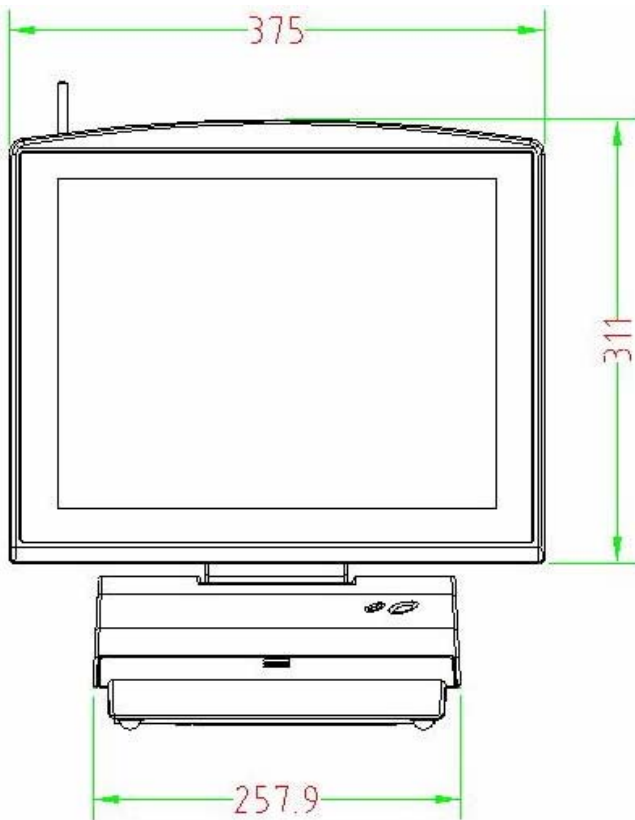

Rear I/O Panel

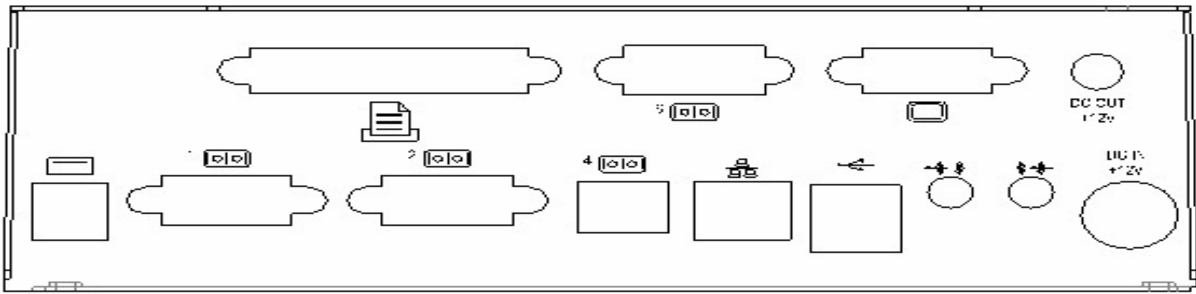

I/O Port	Connector Type	Description
DC12V	DC Power connector	Connect the adaptor to IX800
Cash Drawer	RJ11 connector	Cash Drawer Connector, 12 V Actuation support
Line Out	Earphone connector	Connect the earphone to this port
Mic In	Microphone connector	Connect the microphone to this port
K/B	PS2 connector	Connect the keyboard to this port
LAN	RJ45 connector	Connect IX800 to the Ethernet
COM1、COM2 COM5	D-sub 9 connector	The serial ports COM1/COM2/COM5 can be used to connect serial devices such as a serial printer or a fax/modem.
COM4	VFD/ COM4 RJ45 connector	This RJ45 port is used to attach a VFD customer display or may be used as an additional serial port.
USB	USB type A connector	Standard USB connector for external device

Packing List

- IX800 Main System
- Power adapter
- Driver & Manual CD
- AC power cord

Optional:

- 2nd LCD display
- 32 Key with MSR
- VFD customer display
- Wireless LAN

Chapter 2

Hardware Installation and Upgrading

Warning!



Do not remove the rear cover until you have verified that no power is flowing within the system. Power must be switched off and the power cord must be unplugged. Every time you service the system, you should be aware of this.

2.5" Hard Disk Drive Installation

1. Turn off power and remove power cord from the system

2. Remove the cover of the system bottom by releasing 4 screws in the corner

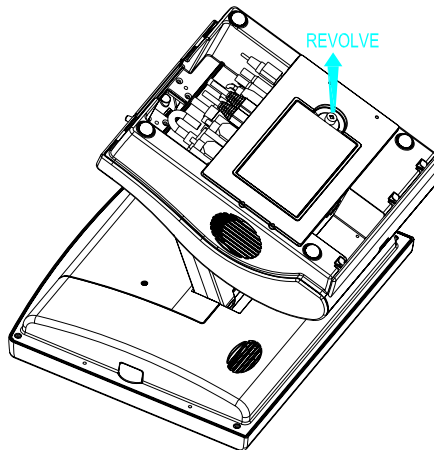

3. Lay the LCD face down on a flat surface and use the 4 screws provided to mount the HDD into the bracketed space

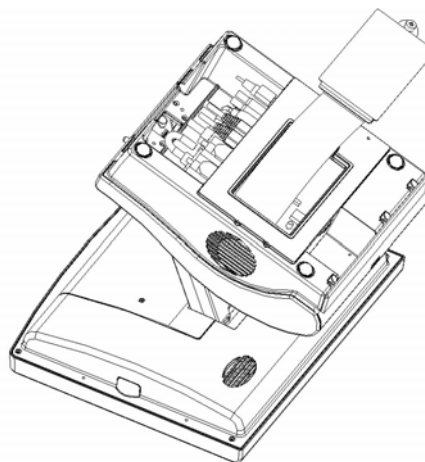

IX800

4. Connect the 44pin ribbon cable to the HDD

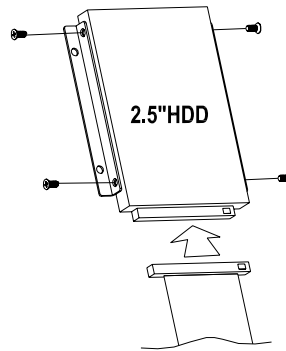

5. Screw the bottom cover back to the system base
6. Connect the power cord to the system

Note: If the HDD does not work normally, please refer to [troubleshooting](#)

MCR Parameter Modification

This option is for users who need to customize the MCR parameters for a particular task. Some of the useful parameters include:

- The selection of country code, other than the default English.
- The choice of track combinations.
- The preamble/postamble codes.

The MCR parameters can be modified by using the supplied utility program. The utility can be found on the CD that came with your system in the "Utilities" folder. The program name is msr_v12_win.zip.

Cash Drawer Installation

Before connecting the cash drawer to the **IX800**, please make sure the drive voltage and cable pin assignment of the cash drawer matches the definition of the cash drawer port of **IX800**. Please refer to **page 21** in the motherboard manual for more information on the Cash Drawer.

Plug cash drawer cable into cash drawer port.

IX800

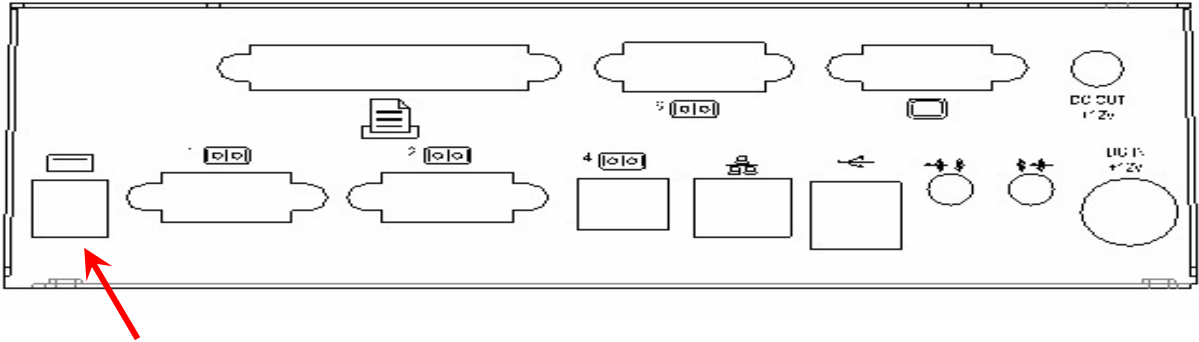

Note: If the cash drawer cannot be detected by the system, please refer to [troubleshooting](#).

Up to two cash drawers may be driven from this port. Driving voltage of the solenoid is DC+12V. I/O port 280h is used for drawer operation. A test program is supplied, for Linux and Windows, source code of which is available on request by software developers.

Hardware logic is as follows.

To open drawer1, write 01h to port 280h, wait 200 msec, then write 00h to turn off the drive.

To open drawer2, write 02h to port 280h, wait 200 msec, then write 00h to turn off the drive.

To test for drawer open, read port **280h**, if bit 0=1 then drawer is open, if bit 0=0 drawer is closed.

Chapter 3

Software Installation and Setup

Driver Installation

IX800 comes with a variety of drivers for different operating systems.

You will find the CD with **IX800** which has all necessary drivers for this system.

Please follow this installation sequence.

Driver installation sequence:

Chipset Driver -> VGA Driver -> LAN Driver -> Audio Driver -> USB Driver -> Touch Tools

The reason to follow our sequence is that IRQ settings will be changed by Windows 2000 and XP to non supported values, and you may encounter unnecessary problems later.

Intel Chipset Driver Installation

1. Insert the CD into your CD ROM Drive.
2. Locate the folder of **D:\Driver\CHIPSET\INF**
3. Open **Setup.exe**

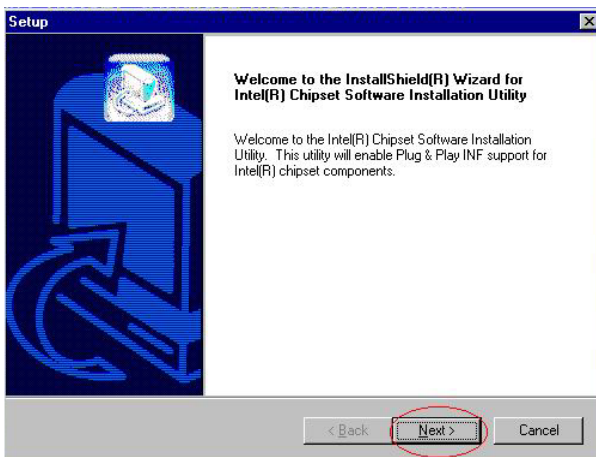

4. Click **Next**.

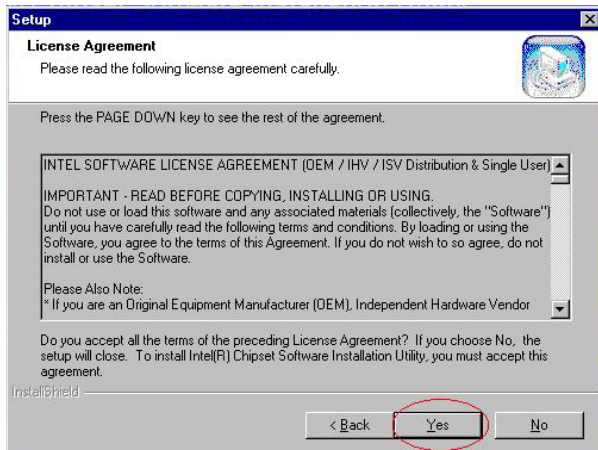

5. Read the License Agreement and click **Yes**.

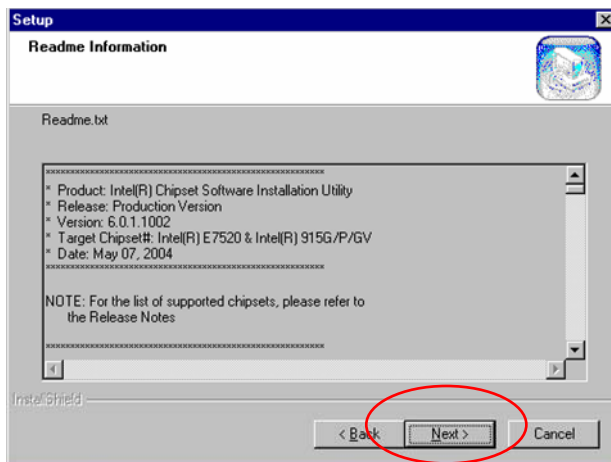

6. Click **Next** and the drivers for the Intel Chip set will install.

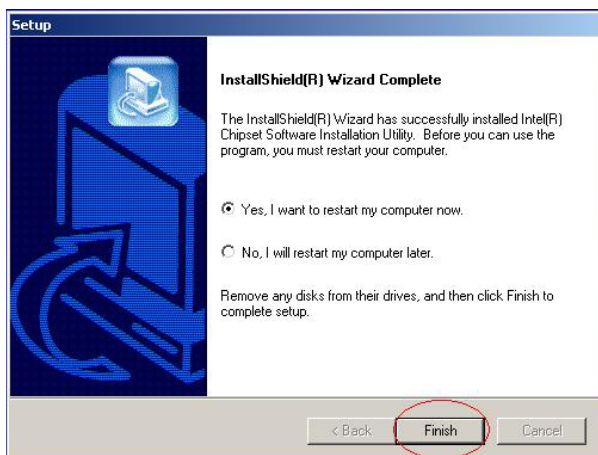

7. When the 'Setup COMPLETE' message appears click **Finish** to restart your computer.

VGA Driver Installation

852GM driver installation Windows 2000 & XP

1. Locate the folder of D:\Driver\VGA\INTEL\WIN2K_XP
2. Open **setup.exe**

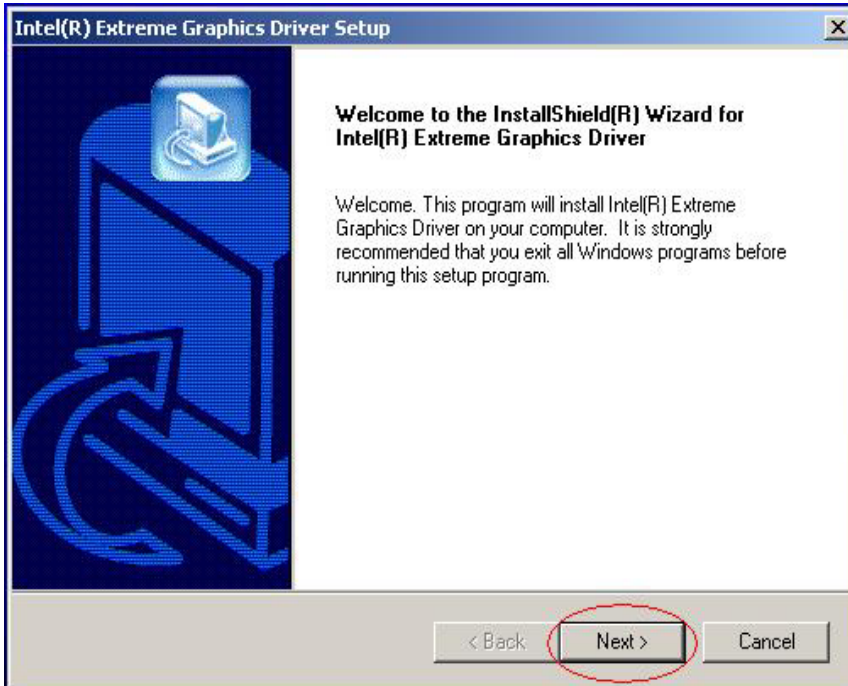

3. Select **Next** to continue.

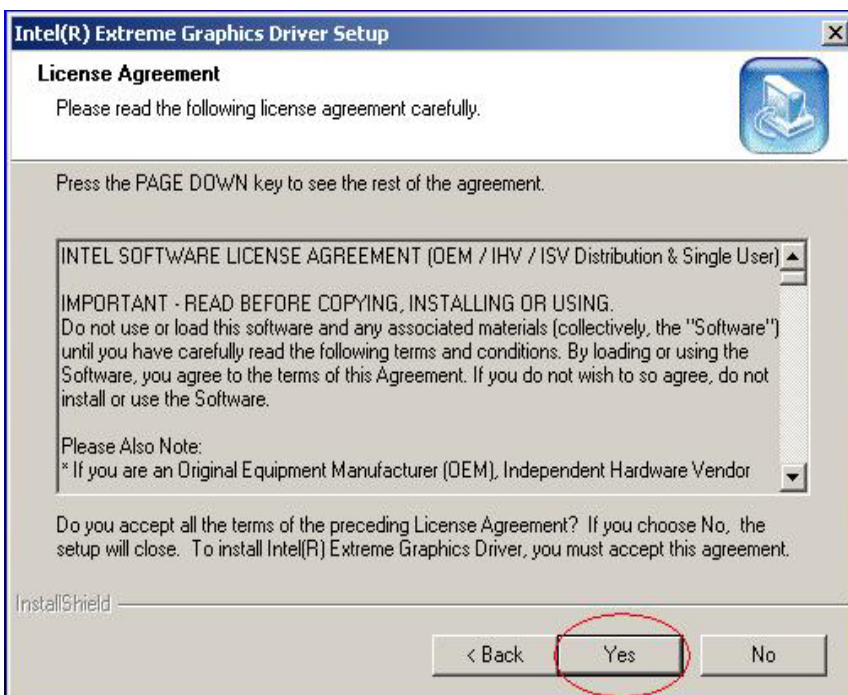

4. Read the License Agreement and click **Yes**.

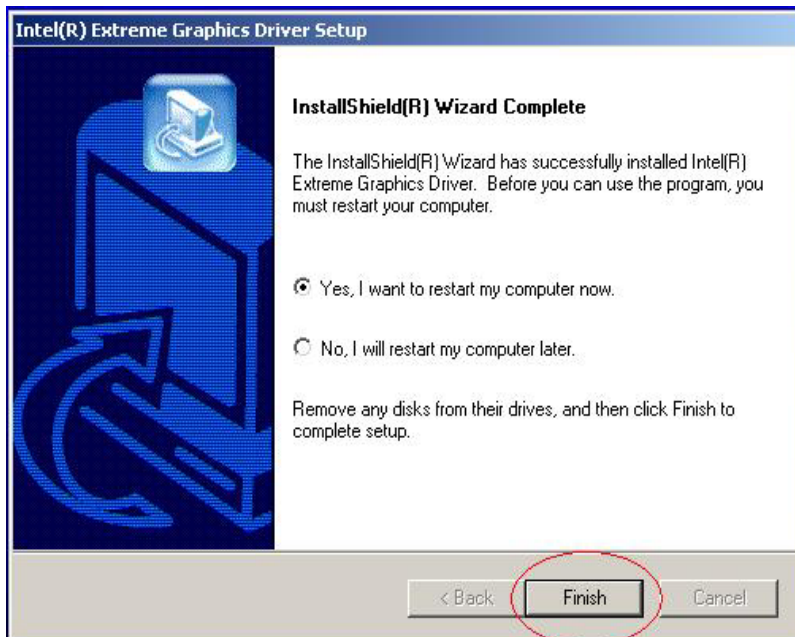

5. Click **Finish** to complete the installation procedure and restart the system.

Enable second LCD panel setting Windows 2000/Windows XP.

After you have installed the VGA driver you must adjust the settings.

1. Right click your mouse anywhere on the desktop then click **properties**.

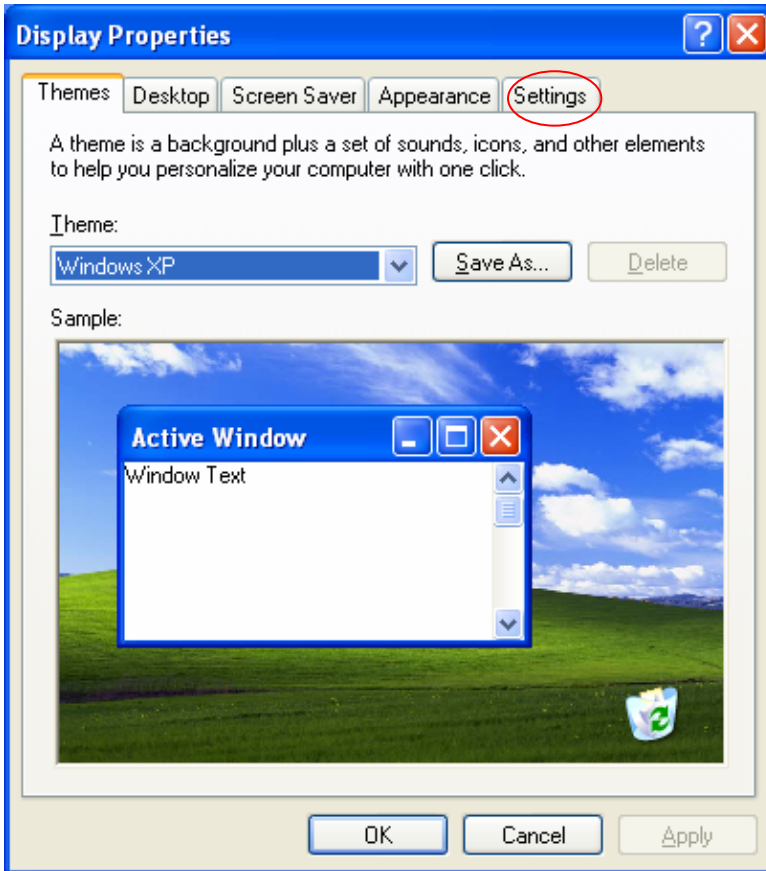

2. Click the **settings** tab.

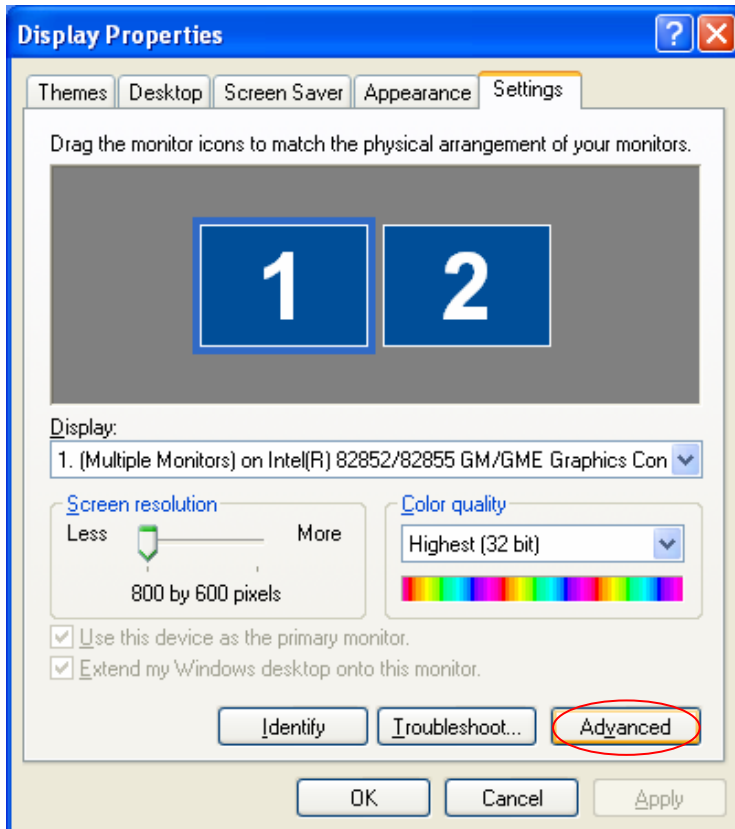

3. Click **Advanced**.

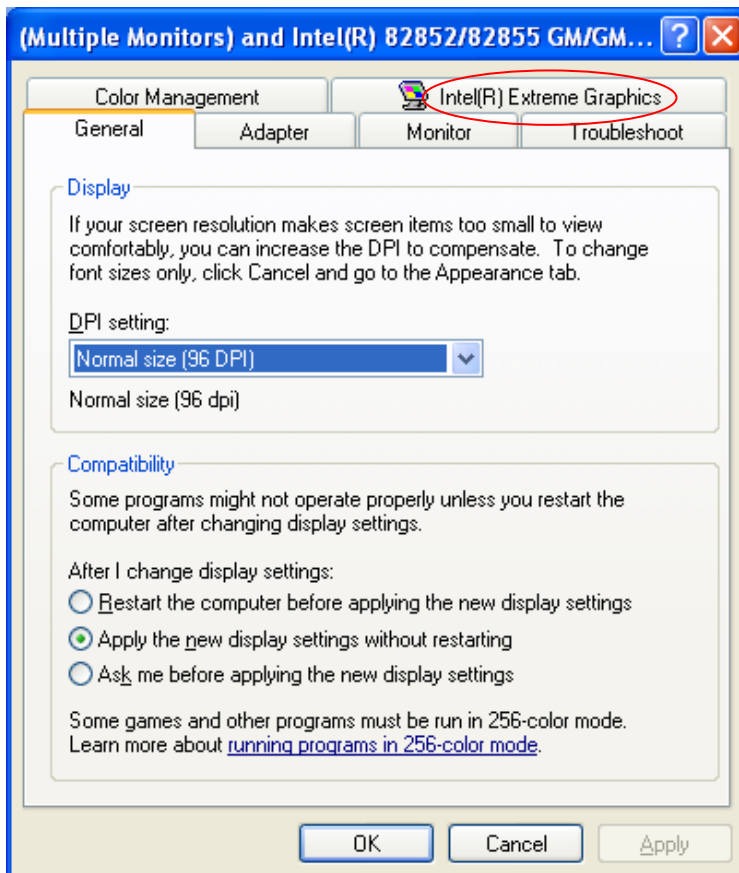

4. Click **Intel(R) Extreme Graphics**.

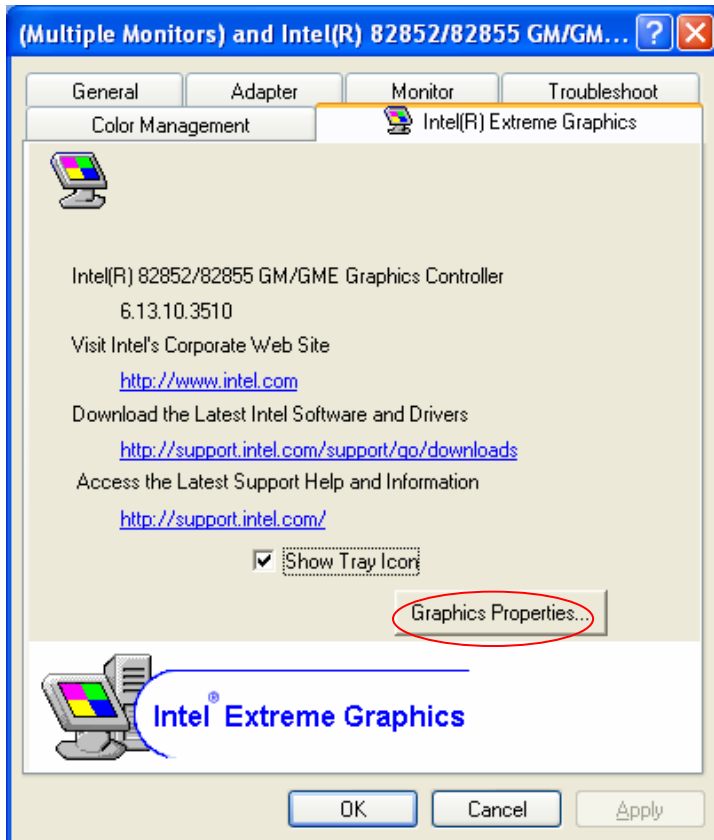

5. Click **Graphics Properties**.

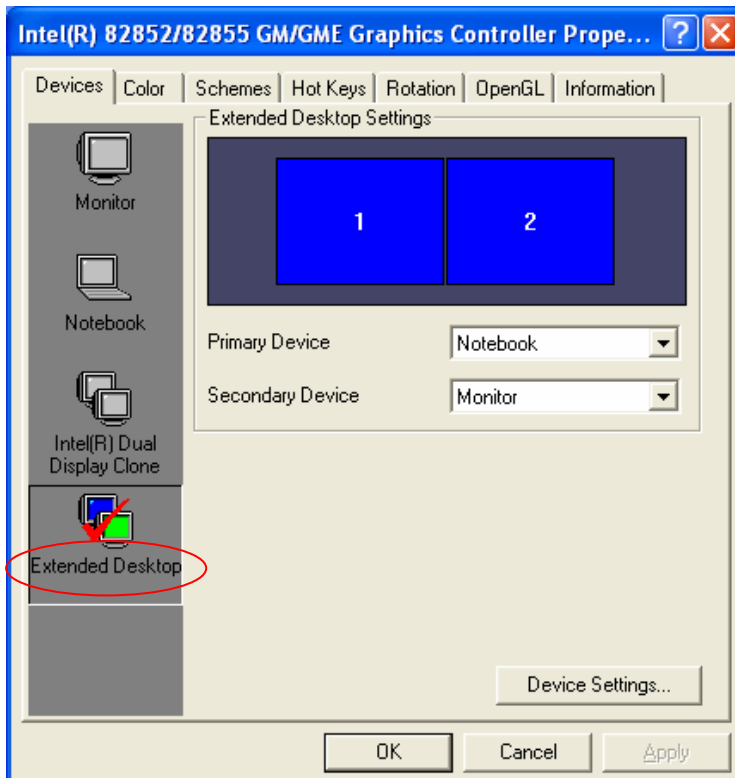

6. Click **Extended Desktop** and select **Notebook** for primary device, **monitor** for secondary device.

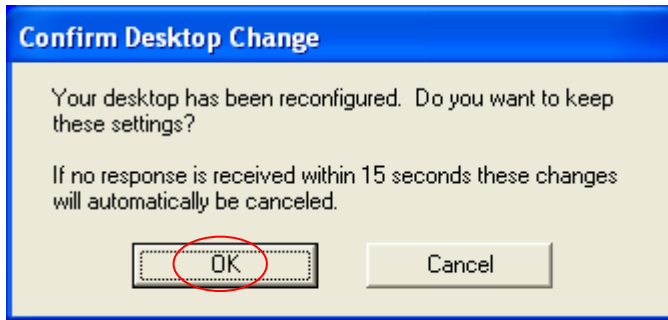

7. Click **OK**.

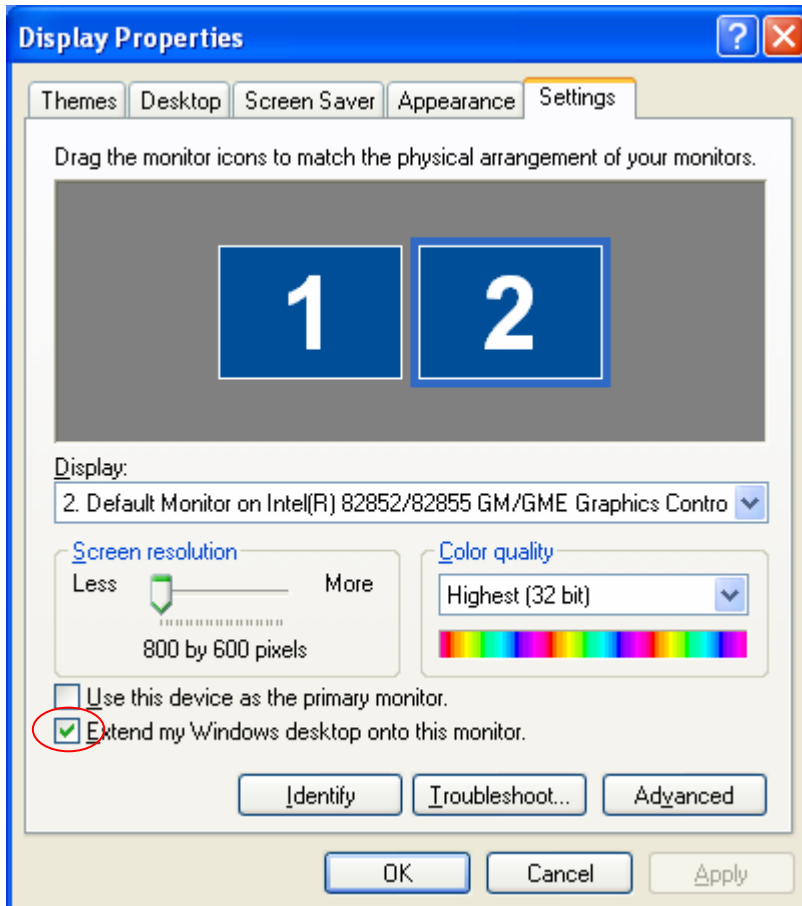

8. Select the second LCD panel. This is done either by clicking on the number 2 or selecting from the dropdown menu.

For the second LCD panel make sure that **Extend my Windows desktop onto this monitor** is selected.

9. Click **Apply** then click **OK** to finish the settings.

Note. During boot sequence “**No Sync**” will appear on the second LCD panel. The boot sequence can take a minute or so when a second LCD panel is installed.

Audio Driver Installation

Audio Driver Installation for all Windows Operating Systems.

1. Locate D:\Driver\audio\Realtek
2. double click Setup.exe.



3. Select **Next** to continue.

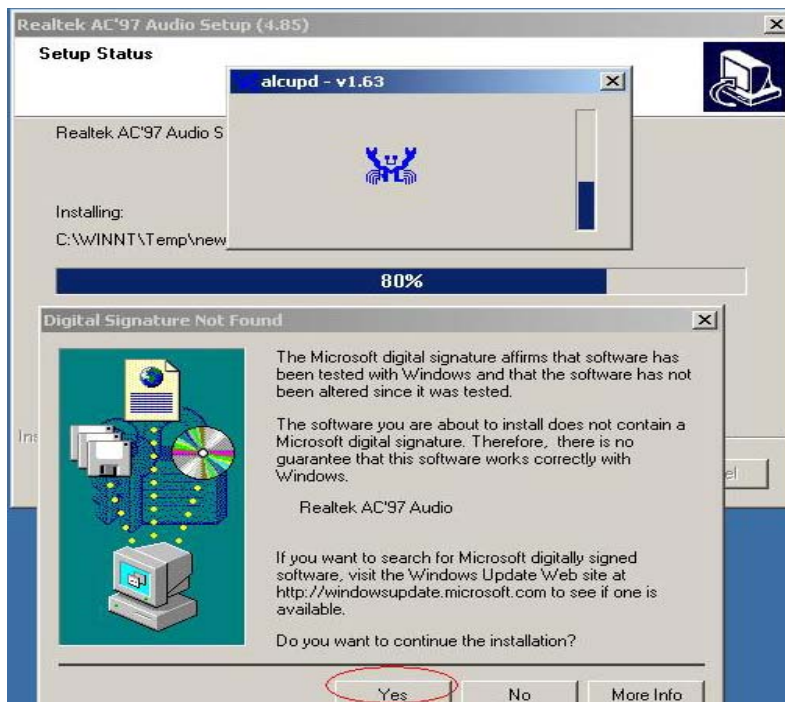

Note: For Windows 2K. If you receive this warning message, please click **Yes** to continue.



Note: For XP If you receive this warning message, please click Continue Anyway.



4. Click **Finish** and restart the system.

USB 2.0 Installation for Windows 2000 and XP

USB 2.0 Drivers are available for download using Windows Update for both Windows XP and Windows 2000. For additional information regarding USB 2.0 support in Windows XP and Windows 2000, please visit www.microsoft.com/hwdev/usb/.

ELO Touch Tools Installation

ELO Touch Tools Installation for Windows 2000 and XP

1. Locate **D:\Utility\TOUCHSCREEN\ELO Touch**
2. Select the relevant ELO folder for the operating system that you are using.

Example. If you are installing for a Windows 2000 or XP then select **Elo Touch 2K_XP**

3. Open **Setup.exe**

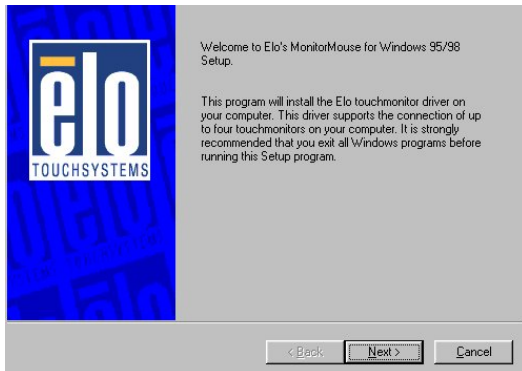

4. Click **Next**



5. Check "Install serial Touch screen Drivers." And Click **Next**.

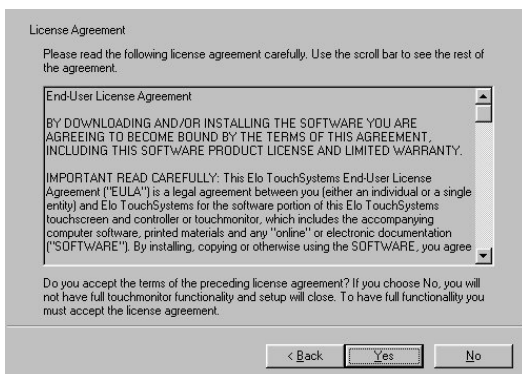

6. Read the **"License Agreement"** and click **Yes** if you accept it.

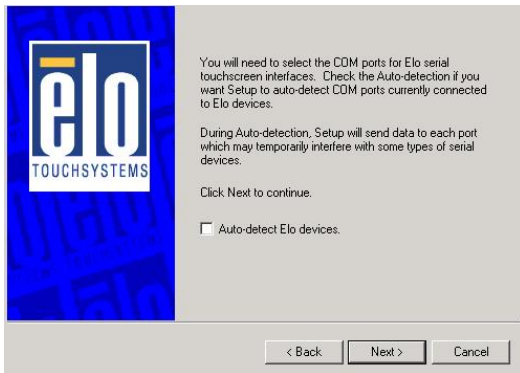

7. Select “Auto-detect Elo devices.” and click **Next**.

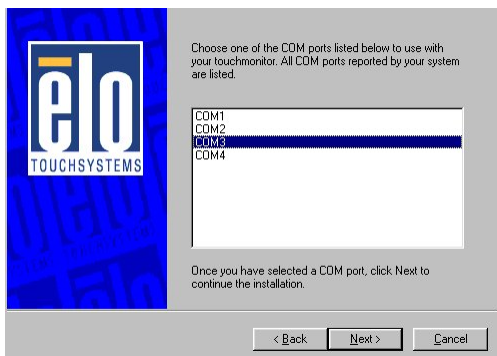

8. Select the COM port for the touch monitor. It is recommended that you select COM3 for the touch screen, as this port is internally configured for touch operation.

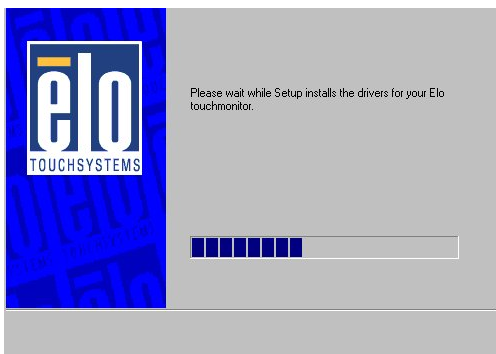

9. Wait until the ELO Touch Tools have been installed.



10. Select View ELO touch screen control panel and click **Finish**.

IX800

IT MAY BE NECESSARY TO RESTART YOUR COMPUTER TO UTILIZE YOUR TOUCHSCREEN FEATURES.

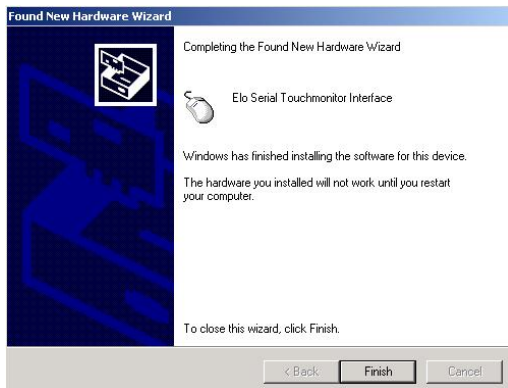

11. Click NEXT while this window appears after system finish rebooting.

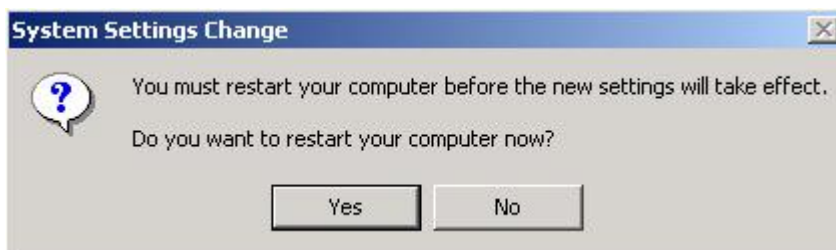

12. Click YES to restart your computer again.

After the system finish rebooting follow the directions to calibrate ELO Touch Tools.

ELO Control Panel

This section explains the different options in the ELO control Panel.

General tab

The general tab allows you to:

- Change the COM port your touch screen is set to.
- Calibrate the touch screen with the **Align** button.



Mode tab

The Buttons tab allows you to:

- Adjust all mouse emulation controls.
- Change cursor properties
- Enable or disable right mouse button utility.

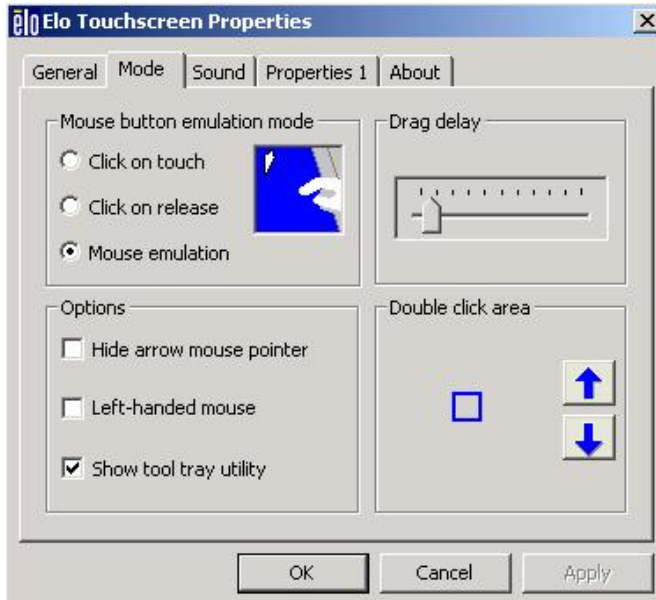

Sound tab

The Sound tab allows you to:

- To change sound properties for ELO touch tools.

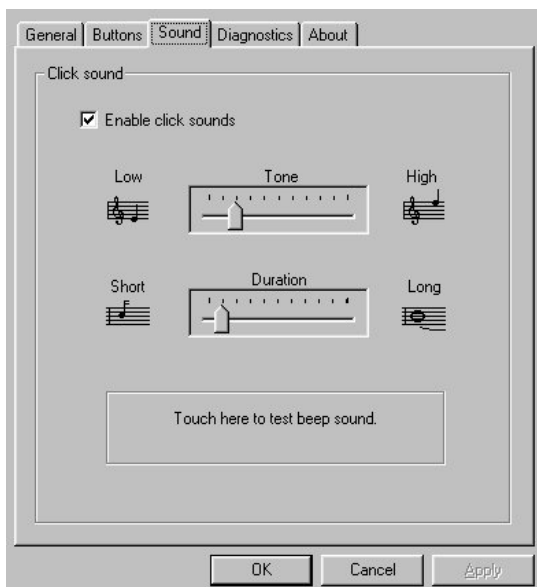

Properties tab

The Diagnostics tab allows you to:

- View Controller Information.

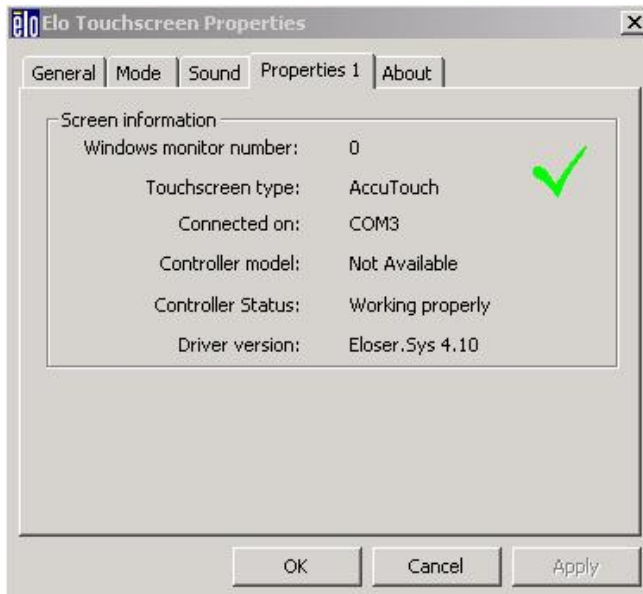

About tab

The About tab displays Information about ELO Touch systems

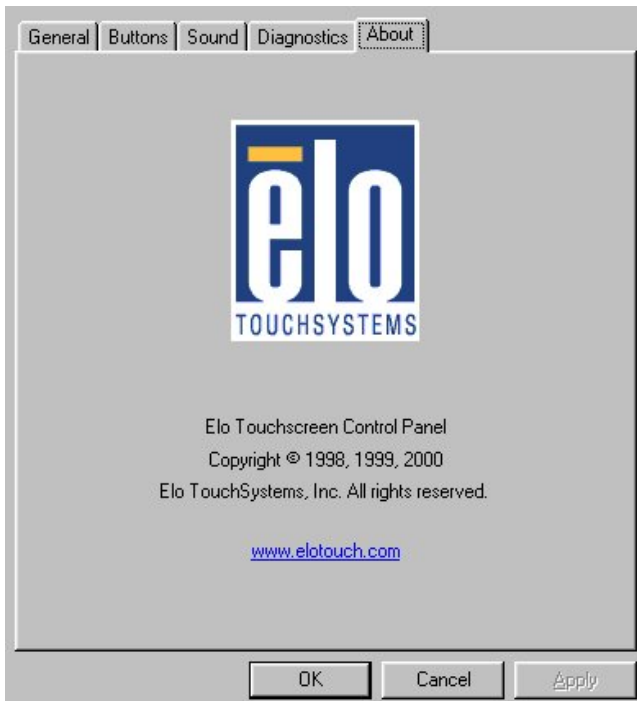

TouchKit Tools Installation

TouchKit Tools Installation for Windows Operating Systems

1. Locate **D:\Utility\TOUCHSCREEN\TouchKit(Fujitsu)\Driver**
2. Select the relevant folder for the operating system that you are using.
3. Open **Setup.exe**

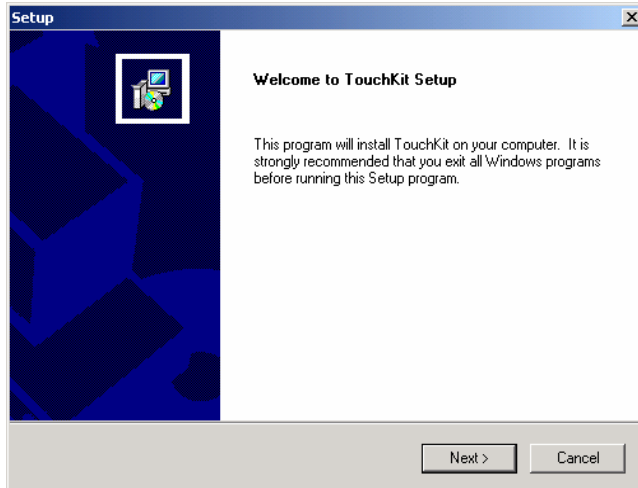

4. Click **Next**

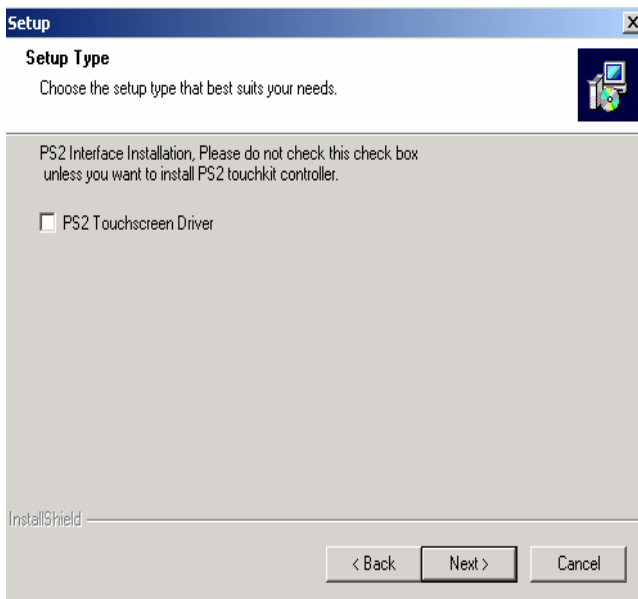

5. Click **Next**

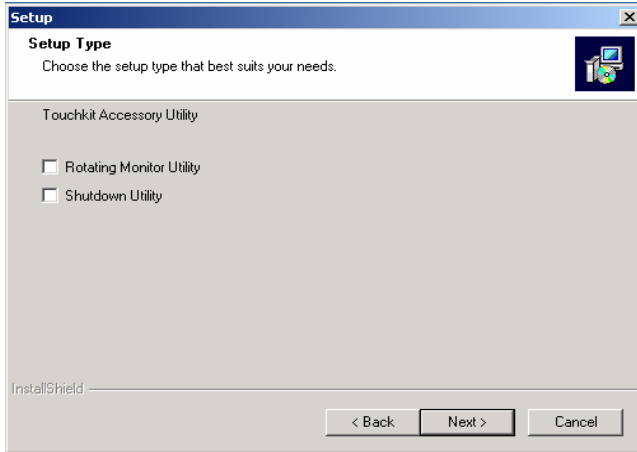

6. Click **Next**

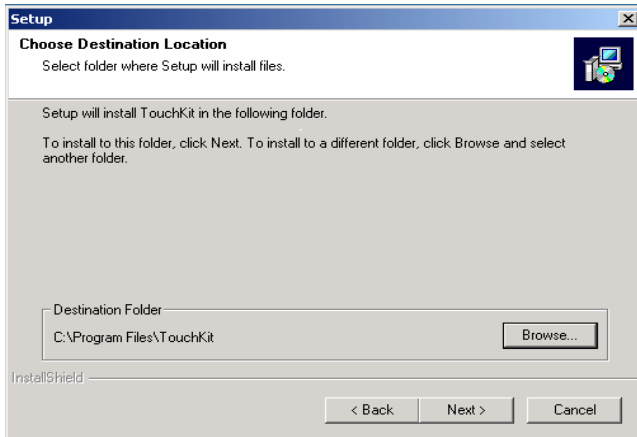

7. Click **Next**

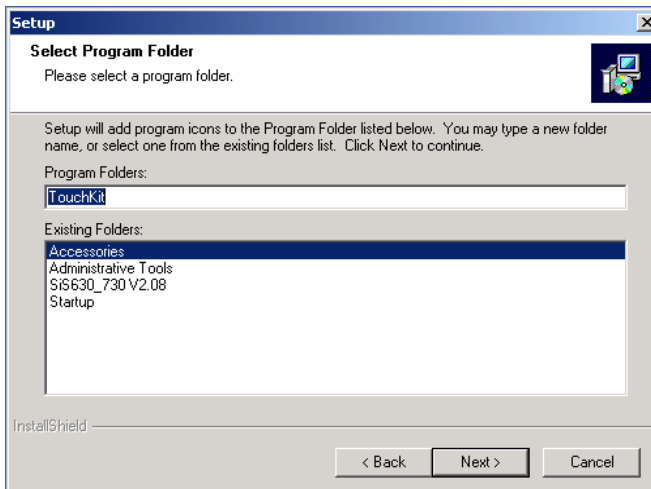

8. Click **Next**

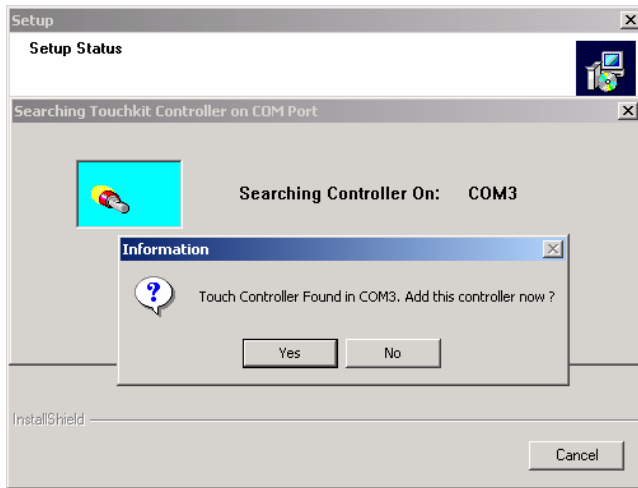

9. Click **Yes**

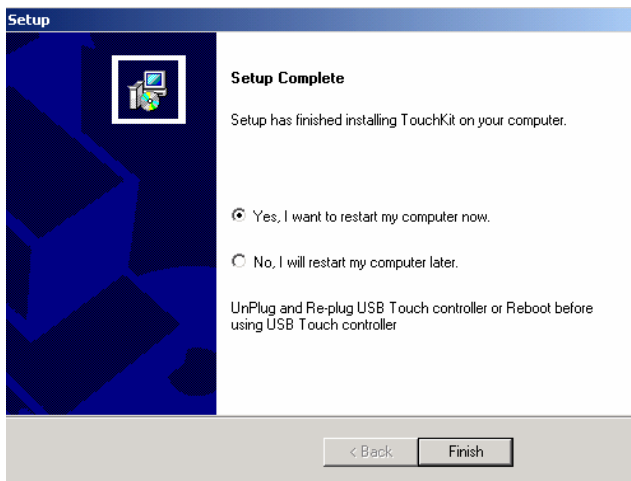

10. Click **Finish** to restart your computer again.

After the system finish rebooting follow the directions to calibrate the Touch screen.

TouchKit Control Panel

This section explains the different options in the TouchKit control Panel.

General tab

The general tab allows you to:

- Change the COM port your touch screen is set to.
- Calibrate the touch screen with the **4 pts Cal** button.

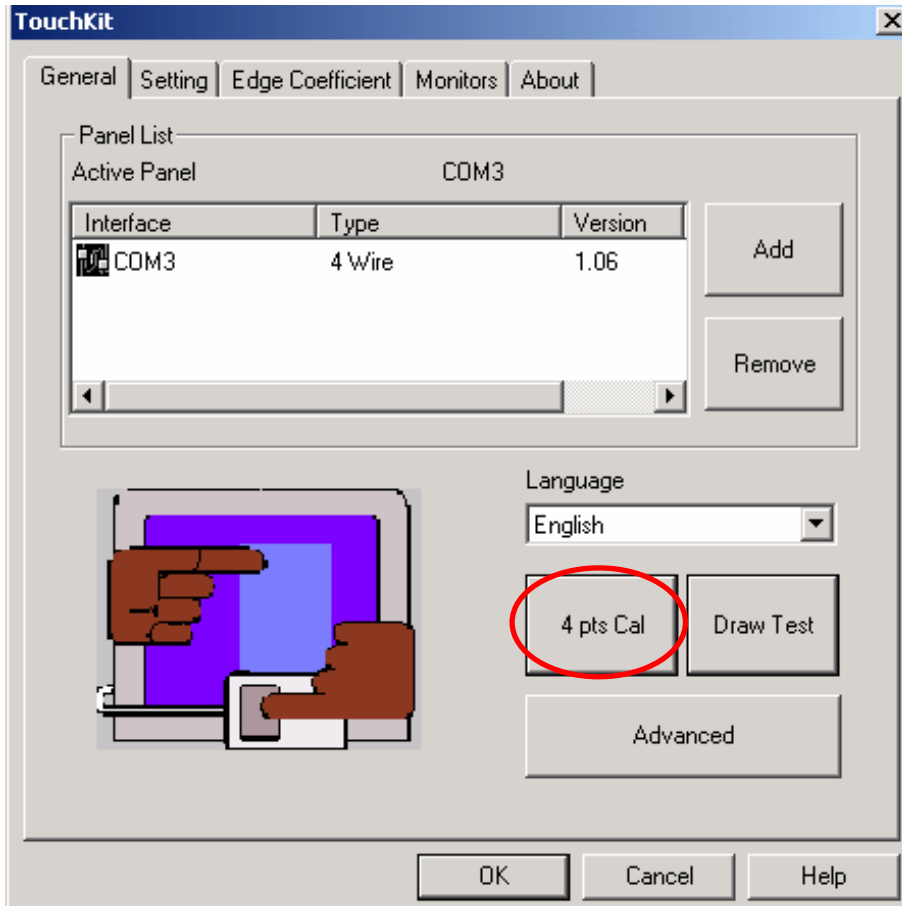

Wireless LAN Driver Installation for Windows Operating Systems (Optional)

1. Run **D:\Utility\Wireless LAN\Winbond\W89C35.exe**

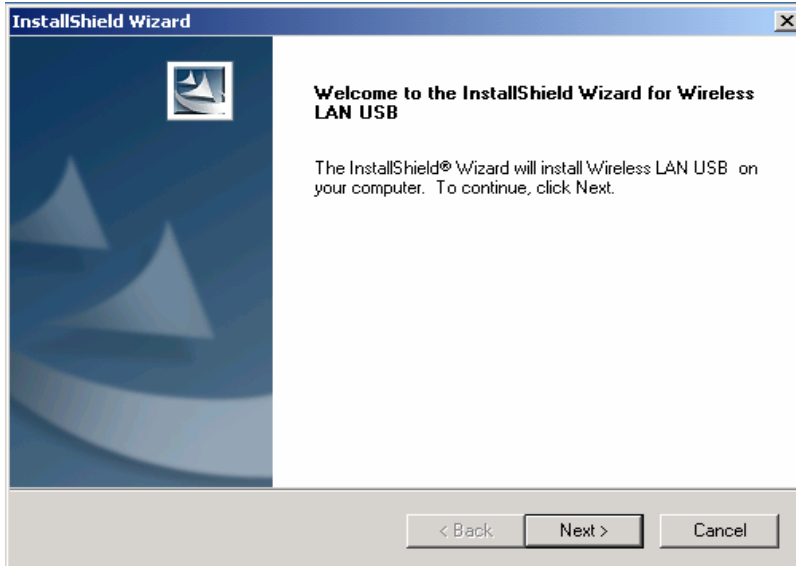

2. Click **Next**

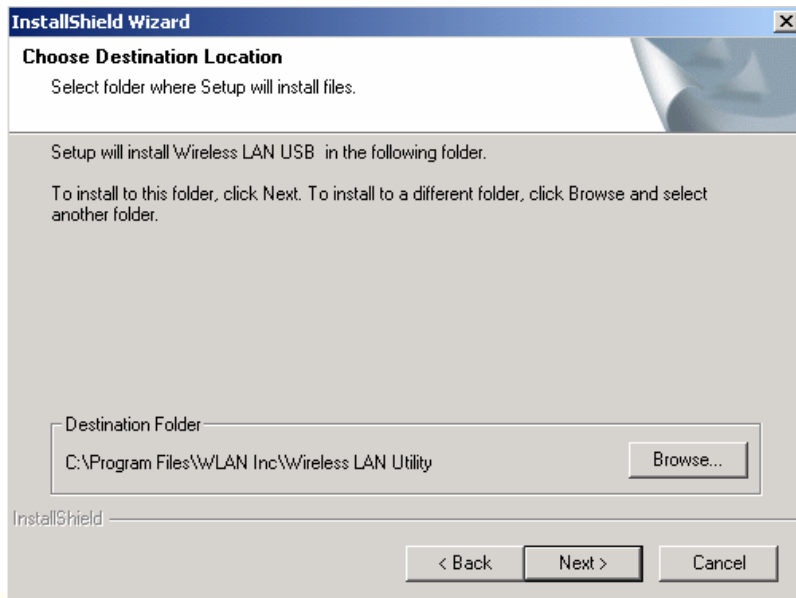

3. Click **Next**

Chapter 4

Specifications

IX800 Specifications

System Configuration	
CPU (BGA 478)	INTEL® Ultra Low Voltage Celeron-M 1GHz w/0K L2
Chipset	i82852GM GMCH + i82801DB ICH4
South Bridge	INTEL 82801DB (ICH4)
Memory	One 200-pin SODIMM support DDR SDRAM up to 1GB
VGA controller	Integrated in 852GM. AGP2.0 4X 3D graphics engine. Shares system DDR SDRAM, 32MB(max).
Primary LCD Panel	15" TFT LCD Panel (800X600/1024x768).
Primary Touch Panel	12" ELO with 4-wire or 15"/17" with ELO 5-wire resistive touch panel.
Storage	Internal 2.5" Parallel ATA 40GB hard disk drive Type I/II Compact Flash™ Disk. IDE interface
Power	150 watt external power adapter.
I/O Port	
Serial Port	3 User available COM ports (COM1, COM2 & COM5). 2 System assigned COM ports (COM3 & COM4). ➤ COM3 for primary touch screen. ➤ COM4 for secondary touch screen or customer character display.
Parallel Port	One Bi-directional Parallel Port supports ECP/EPP (IEEE1284).
USB port	6 USB 2.0 ports (4*External, 2*Internal)
Cash drawer port	RJ11 Cash drawer port ,12V actuation. Controlled through DIO port 280H
Keyboard Port	One PS/2 keyboard port.

IX800

LAN Port	10/100Mbps Ethernet Controller, Realtek RTL8100C
VGA Port	Standard VGA Port for second LCD panel.
Audio Port	Integrated Sound Blaster compatible, AC97 Audio Codec. (Realtek ALC203)
Optional Features	
Customer display	Integrated VFD/LCD customer display.
MSR	External Magnetic Stripe Card Reader track 1/2/3
Identification Device	External Finger Print Receiver and RFID receiver(USB)
Wireless	Internal Wireless Module(USB)
Power Consumption	
Power consumption	60W Idle (Standard system with secondary LCD panel while accessing HDD).
Operating temperature	
Operating temperature	0 °C ~ 40 °C

Motherboard Configuration

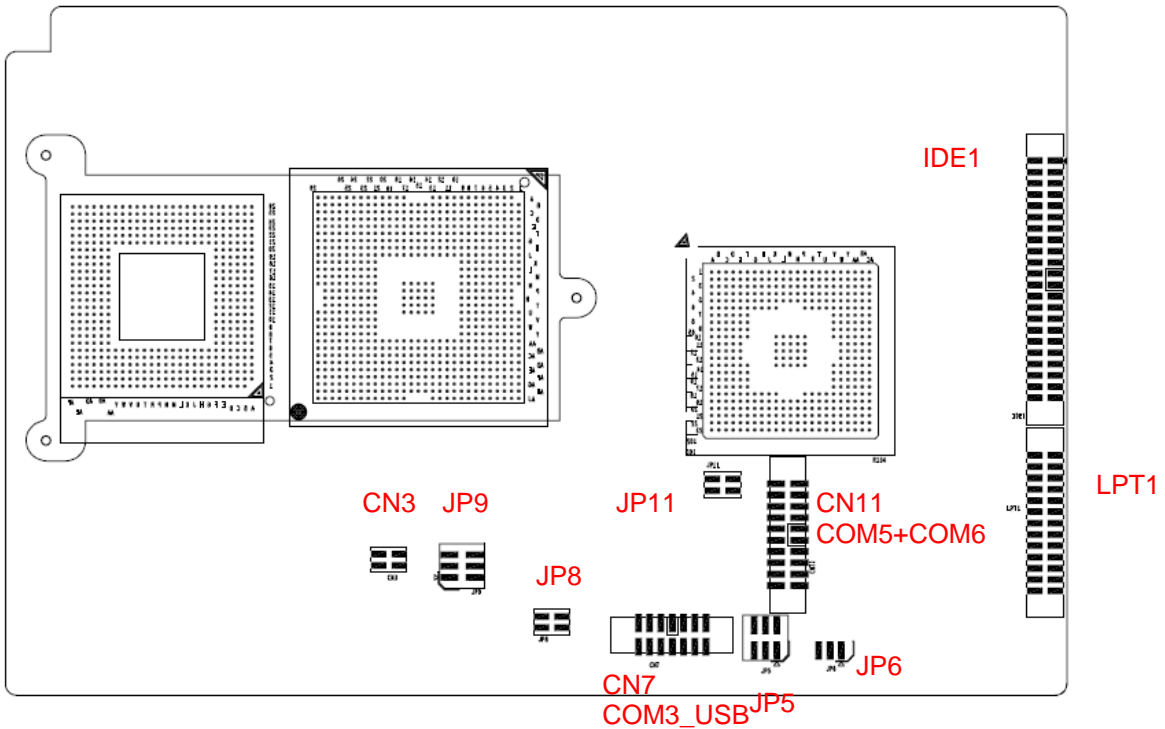
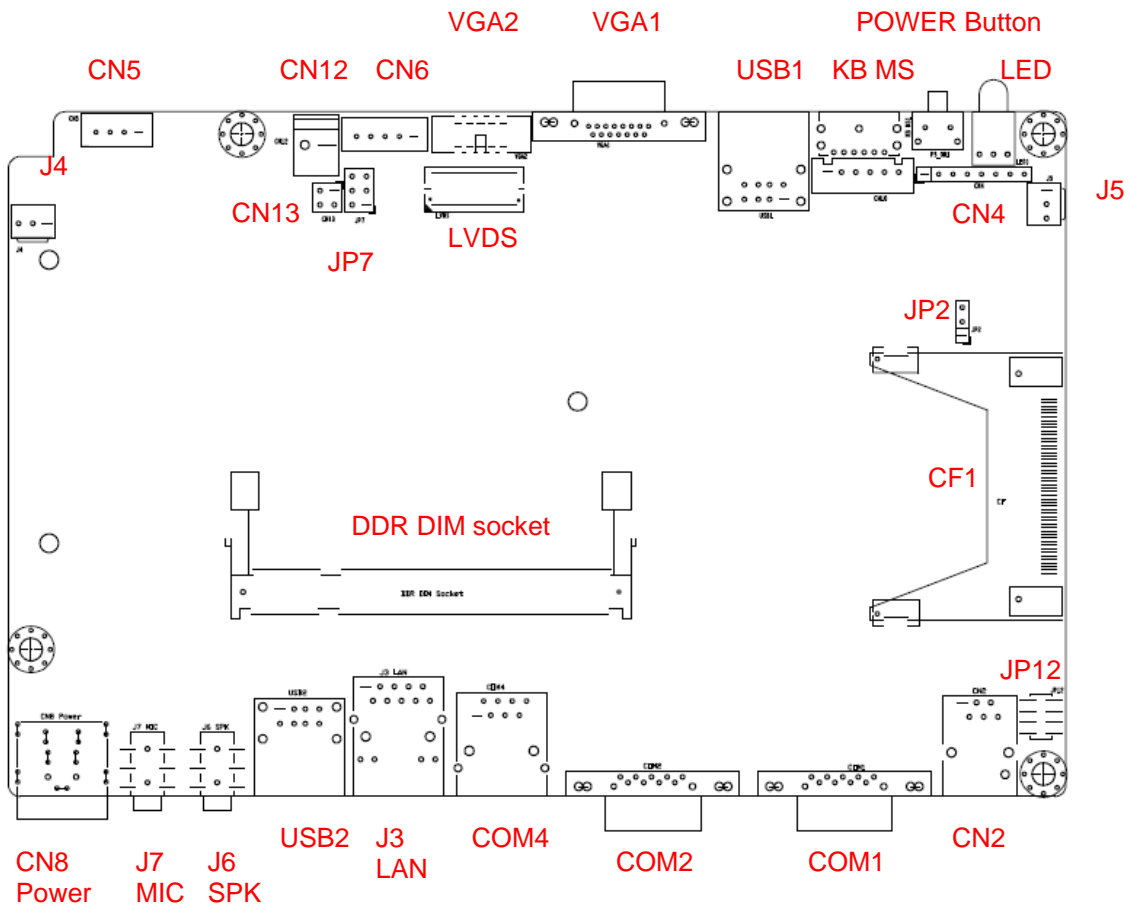

This chapter describes how to connect peripherals, switches and indicators to the **FIR-ULV1000** board.

Label	Function
LVDS1	LVDS LCD Panel connector
VGA1 & 2	VGA connector
LAN	LAN RJ45 connector
USB1	USB dual port connector
USB2	USB dual port connector
COM1	Serial port connectors
COM2	Serial port connectors
COM4	Serial port connectors
KB_MS1	Keyboard & Mouse connector
J4 & J5	Fan connectors
J6 & CN3	Speaker out connector
J7	MIC in connector
LPT1	Parallel port connector
IDE1	Ultra ATA100 Primary IDE connectors
CF1	Compact Flash Storage Card Type II connector
PS_ON1	Power on Switch
LED1	Power LED
CN1	PC/104 Plus connector
CN2	Digital I/O connector
CN4	External switches and indicators
CN5	Power output connector
CN6	LVDS back light connector
CN7	Multi-function connector
CN8	+12V DC power connector
CN10	Internal Keyboard connector
CN11	Serial port connectors (COM5 & COM6)

JP2**Clear CMOS Setup**

JP1	Description
Short 1-2 (default)*	Keep CMOS Setup (Normal Operation)
Short 2-3	Clear CMOS Setup

JP7**TFT LCD Voltage (5V / 3V) Setting**

JP3	Description
Short 1-2	3V TFT LCD

Short 2-3	5V TFT LCD
-----------	------------

JP8 *COM4 Voltage Selection*

JP4	Description
Short 1-2	+12V
Short 3-4	+5V

JP9 *COM4 Mode Selection for VFD (factory default setting)*

JP5	Description
Short 1-2	Short CTS-RTS
Short 3-5	+12/+5V output
Short 4-6	Ground output

COM4 Mode Selection for RS-232 device

JP5	Description
Short 1-3	CTS
Short 2-4	RTS

JP5 *COM2 RI Function Setting*

JP6	Description
Short 1-2	RI is +5V output
Short 3-4	RI function
Short 5-6	RI is +12 Volt output

JP6 *COM1 RI Function Setting*

JP7	Description
Short 1-2	RI is +5 Volt output
Short 3-4	RI function
Short 5-6	RI is +12 Volt output

JP11 *COM5 & COM6 RI Function Setting*

PIN	Description
Short 1-2	RI is +12 Voltage output
Short 3-4	RI is +5 Voltage output

LVDS1 *LVDS Function Setting*

PIN No.	Description	PIN No.	Description
1	GROUND	2	GROUND
3	CH1 DATA3+	4	CH1 DATA3-
5	CH1 CLK+	6	CH1 CLK-
7	CH1 DATA2+	8	CH1 DATA2-
9	CH1 DATA1+	10	CH1 DATA1-
11	CH1 DATA0+	12	CH1 DATA0-
13	GROUND	14	GROUND
15	CH2 DATA3+	16	CH2 DATA3-
17	CH2 CLK+	18	CH2 CLK-
19	CH2 DATA2+	20	CH2 DATA2-
21	CH2 DATA1+	22	CH2 DATA1-
23	CH2 DATA0+	24	CH2 DATA0-
25	GROUND	26	GROUND
27	LCD power	28	LCD power
29	LCD power	30	LCD power

VGA1 *15 Pin Female Connector*

PIN	Description	PIN	Description
1	RED	2	GREEN
3	BLUE	4	NC
5	GROUND	6	GROUND
7	GROUND	8	GROUND
9	VCC / NC	10	GROUND
11	NC	12	DDC DAT
13	HSYNC	14	VSYNC
15	DDCCLK		

VGA2 *10 Pin Box Header Connector*

PIN	Description	PIN	Description
1	RED	6	DDCCLK
2	GREEN	7	DDCDAT
3	BLUE	8	GROUND
4	HSYNC	9	GROUND
5	VSYNC	10	GROUND

LAN1 *RJ45 Connectors (10 / 100M)*

PIN	Description	PIN	Description
1	TX+	7	N/C
2	TX-	8	N/C
3	RX+	9	Speed +
4	N/C	10	Speed -
5	N/C	11	Active/LINK +
6	RX-	12	Active/LINK -

USB1 & USB2 *2 Ports USB Connect (USB 2.0)*

PIN	Description	PIN	Description
1	VCC	5	VCC
2	DATA0-	6	DATA1-
3	DATA0+	7	DATA1+
4	GROUND	8	GROUND

COM1 *D-SUB Serial Port Connector*

PIN	Description	PIN	Description
1	DCD	6	DSR
2	RXD	7	RTS
3	TXD	8	CTS
4	DTR	9	RI
5	GROUND		

COM2 *D-SUB Serial Port Connector*

PIN	Description	PIN	Description
1	DCD	6	DSR
2	RXD	7	RTS
3	TXD	8	CTS
4	DTR	9	RI
5	GROUND		

COM4 *RJ-45 Serial Port Connector*

PIN	Description	PIN	Description
1	+12/+5V	2	+12/+5V or CTS

IX800

3	GROUND	4	GROUND or RTS
5	DTR	6	DSR
7	TXD	8	RXD

COM5 & COM6**Serial Port Box Header Connector**

PIN	Description	PIN	Description
1	(DCD5)	2	(DSR5)
3	(RXD5)	4	(RTS5)
5	(TXD5)	6	(CTS5)
7	(DTR5)	8	(RI5)
9	GROUND5	10	GROUND5
11	(DCD6)	12	(DSR6)
13	(RXD6)	14	(RTS6)
15	(TXD6)	16	(CTS6)
17	(DTR6)	18	(RI6)
19	GROUND6	20	GROUND6

KB_MS1**Mini DIN Keyboard / Mouse Connector**

PIN	Description
1	KEYBOARD DATA
2	MOUSE DATA
3	GROUND
4	+5V
5	KEYBOARD CLOCK
6	MOUSE CLOCK

J4 & J5**CPU FAN & Case FAN Connector**

PIN	Description
1	Rotation Signa
2	+12V
3	I Ground

J6**Speaker out Connector**

PIN	Description	PIN	Description
1	NC	2	GROUND
3-5	Line Out (Left)	4-6	Speaker Out (Right)

J7**Microphone in Connector**

PIN	Description	PIN	Description
1	NC	2	GROUND
3-5	MIC In	4-6	NC

IDE1**IDE Interface connector**

PIN	Description	PIN	Description
1	RESET#	2	GROUND
3	DATA 7	4	DATA 8
5	DATA 6	6	DATA 9
7	DATA 5	8	DATA 10
9	DATA 4	10	DATA 11
11	DATA 3	12	DATA 12
13	DATA 2	14	DATA 13
15	DATA 1	16	DATA 14
17	DATA 0	18	DATA 15
19	GROUND	20	N/C
21	DRQ	22	GROUND
23	IOW#	24	GROUND
25	IOR#	26	GROUND
27	CHRDY	28	REV. PULL LOW
29	DACK	30	GROUND
31	INTERRUPT	32	N/C
33	SA1	34	PD66 SELECT
35	SA0	36	SA2
37	HDC CS0#	38	HDC CS1#
39	HDD ACTIVE#	40	GROUND
41	+5V	42	+5V
43	GND	44	N/C

LPT1**LPT1 Box Header connector**

PIN	Description	PIN	Description
1	STROBE#	14	AUTO FORM FEED #
2	DATA 0	15	ERROR#
3	DATA 1	16	INITIALIZE
4	DATA 2	17	PRINTER SELECT IN#
5	DATA 3	18	GROUND
6	DATA 4	19	GROUND
7	DATA 5	20	GROUND
8	DATA 6	21	GROUND
9	DATA 7	22	GROUND

IX800

10	ACKNOWLEDGE	23	GROUND
11	BUSY	24	GROUND
12	PAPER EMPTY	25	GROUND
13	PRINTER SELECT	26	NC

CF1**Compact Flash Storage Card Socket pin assignment**

PIN	Description	PIN	Description
1	GROUND	26	PULL DOWN
2	D3	27	D11
3	D4	28	D12
4	D5	29	D13
5	D6	30	D14
6	D7	31	D15
7	CS1#	32	CS3#
8	N/C	33	N/C
9	GROUND	34	IOR#
10	N/C	35	IOW#
11	N/C	36	VCC
12	N/C	37	IRQ15
13	VCC	38	VCC
14	N/C	39	MASTER/SLAVE
15	N/C	40	N/C
16	N/C	41	RESET#
17	N/C	42	IORDY
18	A2	43	DREQ
19	A1	44	DACK#
20	A0	45	ACTIVE#
21	D0	46	PDIAG#
22	D1	47	D8
23	D2	48	D9
24	N/C	49	D10
25	PULL DOWN	50	GROUND

CN2**DGI/O Connector**

PIN	Description	PIN	Description
1	GROUND	2	DGI/O OUT 0
3	DGI/O IN 0	4	+12V
5	DGI/O OUT 1	6	GROUND

CN3 *Line out connector*

PIN	Description	PIN	Description
1	LINE Out (Left)	2	GROUND
3	LINE Out (Right)	4	GROUND

CN4 *Power SW/ LED Connector*

PIN	Description	PIN	Description
1	LED ON +	2	LED OFF +
3	GROUND	4	PS ON

CN5 *Connector*

PIN	Description	PIN	Description
1	VCC5V	2	GROUND
3	GROUND	4	VCC12V

CN6 *LCD Back Light Connector*

PIN	Description	PIN	Description
1	+12V	2	+12V
3	GROUND	4	GROUND
5	Back Light enable		

CN7 *Multi-function connector (USB 2.0 and COM3)*

PIN	Description	PIN	Description
1	+5V	2	+5V
3	USB- (USB2.0)	4	USB- (USB2.0)
5	USB+ (USB2.0)	6	USB+ (USB2.0)
7	GROUND	8	GROUND
9	DTR	10	CTS
11	RTS	12	TX
13	RX	14	DSR

CN8 *+12V DC Power Connector*

PIN	Description	PIN	Description
1	+12V	2	GROUND
3	+12V	4	GROUND

CN10 6 Pin Keyboard Connector

PIN	Description
1	+5V
2	KEYBOARD CLOCK
3	PC KB CLOCK
4	KEYBOARD DATA
5	PC KB DATA
6	GROUND

J2&J3**KB/MSR and W/IC Card Reader**

J1	
1-3	Short
2-4	Short

USB2 Signal routing Jumper mode 1 (factory default setting)

USB2 go directory to CON3 SCSI II Connector reserved for USB wireless LAN

J2	
3-5	Short
4-6	Short

J3	
1-3	Short
2-4	Short

USB2 Signal routing Jumper mode 2

USB2 go via K/B with USB Hub (9000CB0770) and back to CON3 SCSI II Connector

J2	
1-3	Short
2-4	Short

J3	
3-5	Short
4-6	Short

I/O board Configuration

RG9000PB2130 I/O Board Pin Definition

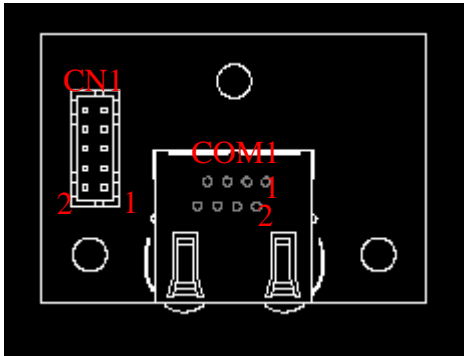

CN1 Com5 2x5 pin wafer connector connects to the mainboard CN11

CN1			
PIN NO.	DESCRIPTION	PIN NO.	DESCRIPTION
1	N/C	2	(DSR)
3	(RXD)	4	N/C
5	(TXD)	6	N/C
7	(DTR)	8	12V
9	GROUND	10	GROUND

COM1 COM5 RJ45 Connector used for VFD

COM1			
PIN NO.	DESCRIPTION	PIN NO.	DESCRIPTION
1	+12	5	DTR
2	+12	6	DSR
3	GROUND	7	TXD
4	GROUND	8	RXD

RG9000PB2140 I/O Board Pin Definition

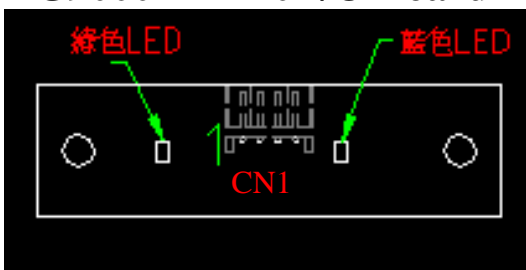

CN1 LED 1x4 pin 90D wafer connector connects to the mainboard CN4

CN1	
PIN NO.	DESCRIPTION

1	ON_LED
2	GROUND
3	VCC5
4	IDE_LED

RG9000PB2150 I/O Board Pin Definition

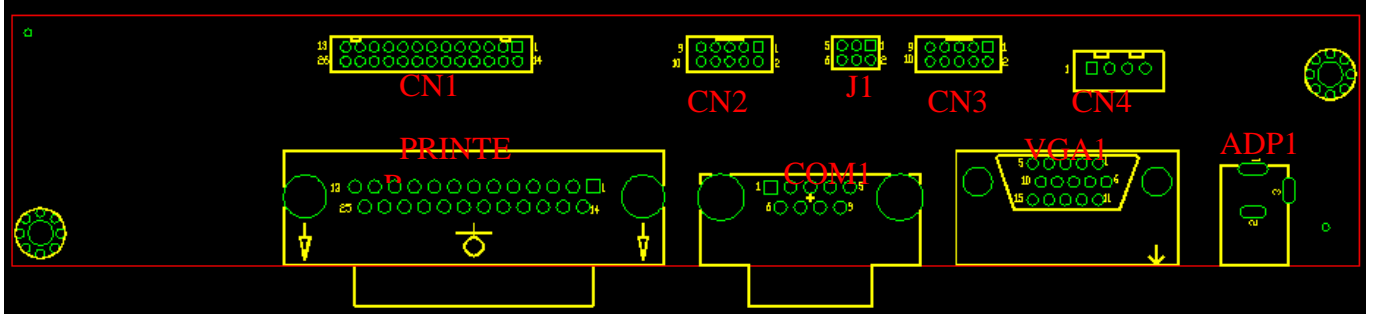

J1 COM6 Voltage Selection

J1	
PIN STATE	DESCRIPTION
Short 1-2	+12V
Short 5-6	★+5V

CN1 Parallel port 2x13 pin header connector connects to the mainboard LPT1

CN1			
PIN NO.	DESCRIPTION	PIN NO.	DESCRIPTION
1	STROBE#	14	AUTO FORM FEED #
2	DATA 0	15	ERROR#
3	DATA 1	16	INITIALIZE
4	DATA 2	17	PRINTER SELECT IN#
5	DATA 3	18	GROUND
6	DATA 4	19	GROUND
7	DATA 5	20	GROUND
8	DATA 6	21	GROUND
9	DATA 7	22	GROUND
10	ACKNOWLEDGE	23	GROUND
11	BUSY	24	GROUND
12	PAPER EMPTY	25	GROUND
13	PRINTER SELECT	26	N/C

CN2 Com6 2x5 pin wafer connector connects to the mainboard CN11

CN2			
PIN NO.	DESCRIPTION	PIN NO.	DESCRIPTION

IX800

1	(DCD)	2	(DSR)
3	(RXD)	4	(RTS)
5	(TXD)	6	(CTS)
7	(DTR)	8	+12V
9	GROUND	10	GROUND

CN3 VGA 2x5 pin wafer connector connects to the mainboard VGA2

CN3			
PIN NO.	DESCRIPTION	PIN NO.	DESCRIPTION
1	RED	2	DDCCLK
3	GREEN	4	DDCDAT
5	BLUE	6	GROUND
7	HSYNC	8	GROUND
9	VSYNC	10	GROUND

CN4 Power 1x4 pin wafer connector connects to the mainboard CN5

CN4	
PIN NO.	DESCRIPTION
1	+5V
2	GROUND
3	GROUND
4	+12V

PRINTER Parallel port LPT1 D-SUB connector

PRINTER			
PIN NO.	DESCRIPTION	PIN NO.	DESCRIPTION
1	STROBE#	14	AUTO FORM FEED #
2	DATA 0	15	ERROR#
3	DATA 1	16	INITIALIZE
4	DATA 2	17	PRINTER SELECT IN#
5	DATA 3	18	GROUND
6	DATA 4	19	GROUND
7	DATA 5	20	GROUND
8	DATA 6	21	GROUND
9	DATA 7	22	GROUND
10	ACKNOWLEDGE	23	GROUND
11	BUSY	24	GROUND
12	PAPER EMPTY	25	GROUND
13	PRINTER SELECT	26	N/C

COM1 RS232 port Com6 D-SUB connector

COM1			
PIN NO.	DESCRIPTION	PIN NO.	DESCRIPTION
1	(DCD)	2	(DSR)
3	(RXD)	4	(RTS)
5	(TXD)	6	(CTS)
7	(DTR)	8	+5V or +12V
9	GROUND	10	GROUND

VGA1 VGA port

VGA1			
PIN NO.	DESCRIPTION	PIN NO.	DESCRIPTION
1	RED	2	GREEN
3	BLUE	4	NC
5	GROUND	6	GROUND
7	GROUND	8	GROUND
9	VCC / NC	10	GROUND
11	NC	12	DDC DAT
13	HSYNC	14	VSYNC
15	DDCCLK		

ADP1 DC JACK Connector 12V

ADP1	
PIN NO.	DESCRIPTION
1	+12V
2	Ground
3	N/C

Chapter 5

Troubleshooting

Please note that the following troubleshooting guide is designed for people with strong computer hardware knowledge such as System Administrators and Engineers.

Power is on, but there is no Panel Display

- A) Check that the motherboard Power LED is on when the power adapter power switch is in the on position.
Ensure that the correct AC voltage is selected (the voltage switch is located beside the power switch).
- B) Check that the Power are running when system power is on.
 - B-1) Check whether the ATX power switch cable is properly connected to motherboard CN2 (Please refer to page7 in the **FIR-ULV1000** User's guide).
- C) Please ensure that the IDE cable is properly connected to the HDD and the red stripe on the ribbon cable should align with IDE1 on the IDE connector of HDD.
- D) Reset CMOS DATA by shorting motherboard JP1 PIN2 and PIN3 for a few seconds (Please refer to page49 in the **FIR-ULV1000** User's guide).
- E) Check if the system is beeping.
 - E-1) A single long repeated beep indicates that a DRAM error has occurred. Make sure DRAM is properly installed or replace DRAM.
 - E-2) One short beep after power on, means system is ok, but LCD panel or VGA interface could be defective.
 - E-2-1) INIT display should be set for AGP in the COMS setup.
 - E-2-2) LVDS board connection to motherboard LVDS1 could be defective.
 - E-2-3) The connection between the LVDS board and the LCD panel is not completely.
 - E-2-4) The LCD cable could be defective.
 - E-2-5) The Inverter cannot produce backlight.
 - E-2-6) The LCD panel could be defective.

To check where the problem could be:

Please connect a VGA monitor to the VGA port. If the VGA monitor is display normally, one of the problems above is occurring, otherwise it could be the motherboard is not functioning properly.

Cannot Detect HDD

- A) IDE cable is not connected properly to motherboard IDE1 or it could be defective.
- B) HDD power cable is not connected properly to the I/O board or it could be defective.
- C) Check CMOS setup, set IDE HDD to Auto detects.
- D) On-board IDE port could be defective.

Touch Panel Does not Work

- A) Check CMOS settings, COM3 needs to be "Enabled". The correct settings are "3E8h" and "IRQ10".
- B) Check that there are no conflicts between COM3 IRQ10 and any other devices.
- C) Check that the ELO driver or the TouchKit driver has been properly installed. Or try to re-install again (Please refer to the ELO driver installation or the TouchKit driver).
- D) Check that the ELO controller or the TouchKit driver on COM3 has been detected during the ELO driver or the TouchKit driver installation. If yes, then check that the flat cable from the ELO touch screen or the TOUCHKIT touch screen has been properly connected to the ELO controller or the TouchKit controller (**Attention:** Pin1 mark should be on the same side as the ELO controller).
- E) Check that the ELO controller or the TouchKit controller Green LED is blinking?
If no, there is no DC+5V support for the ELO controller or the TouchKit controller from the motherboard.
 - E-1) Check that the COM3 cable is properly connected between motherboard CN5 and the Touch screen controller.
- F) Touch screen controller could be defective or the touch panel could be defective.

ELO Touch Panel Cannot Calibrate Correctly

- A) Please replace the ELO controller, and re-calibrate. If this works, change back to the original ELO controller, and re-calibrate.
- B) If the ELO touch panel still cannot calibrate correctly after changing to a new ELO controller, the touch panel may be not installed properly or it could be defective.

PS/2 Keyboard is not Functioning Normally

- A) Make sure the keyboard is properly connected to the PS/2 keyboard port before the system is powered up. If the keyboard is connected after Windows2000 has been booted, the keyboard will not work.
- B) Check that the LED on the keyboard goes on then off after power on. If yes, the keyboard is getting power correctly.
- C) If the MCR is not required. Please make sure the loopback is plugged into the MCR connector board.
- D) Check that the 6-wire cable has been properly connected between the MCR connector board and motherboard KB1
The motherboard KB1 cable can be removed. Then short Pins 2-3 and Pins 4-5 If the keyboard still does not work, then check next step. Otherwise, the cable or MCR connector board could be defective.
- E) The motherboard could be defective.

MCR is not Functioning Properly

- A) Check if the green MCR LED is on.
 - A-1) Check if the MCR is properly connected to the MCR connector board on main system.
 - A-2) Make sure the 6 wire cable is properly connected between 9000PB0610 I/O board CN20 and the MCR connector board.
 - A-3) The MCR connector board could be defective.
 - A-4) The MCR module could be defective.
- B) If a keyboard is connected to the PS/2 keyboard port, and functions correctly, then the MCR module could be defective.

VFD Display is not Functioning Properly

- A) Ensure that COM4 is enabled in the CMOS setup, and data is written to COM4 in the application.
- B) Check if there is any display when system power is ON, if the screen is blank, please follow the steps below.
 - B-1) Make sure the power switch on the VFD display is on before powering the main system.
 - B-2) Make sure that the motherboard JP4 & JP5 jumper settings are correct.
The proper settings are:
JP4 Pins 1-2 shorted
JP5 Pins 1-2, Pins 3-5 and Pins 4-6 shorted
- C) The on-board COM4 I/O chips could be defective.

LAN is not Functioning Properly

- A) Check if the LAN driver is installed properly. (Please refer to the LAN driver installation)
- B) Check if there are any IRQ conflicts.
- C) Check if the RJ45 cable is properly connected.
- D) The on board LAN chip could be defective.

COM1, COM2, COM5 are not Functioning Properly

- A) Check if the I/O ports are enabled in the CMOS setup.
- B) Check if there are any IRQ conflicts.
- C) The motherboard could be defective.

Cash Drawer Port is not Functioning Properly

- A) Make sure the pin assignment matches between the cash drawer and the RJ11 cash drawer port.
- B) Verify the digit I/O port address and bit are “280h” respectively. Command send “L” level for 200ms (Refer to **FIR-ULV1000** user’s manual page).
- C) The motherboard could be defective.

USB Device is not Functioning Properly

- A) Ensure that the USB controller is “enabled” in the CMOS setup.
- B) Ensure that the USB Legacy is “enabled” in the CMOS setup. (Windows 98 · Windows 2000 · Window XP Professional)
- C) Ensure that the USB Legacy is “Disabled” in the CMOS setup. (Embedded OS: Windows XP Embedded · Window CE. NET · Linux RedHat 9)